



**GOVT. POLYTECHNIC BARGARH**

**LECTURE NOTE**

**ENERGY CONVERSION-I**

**SEMESTER-4<sup>TH</sup>**

**ELECTRICAL ENGG**

**PREPARED BY,**

**NITESH KUMAR ACHARYA**

**Lecturer in Electrical Engineering**

## COURSE OUTCOME OF ENERGY CONVERSION-I

---

After completion of the course students will be able to:-

CO1	Understand/Explain the construction, principle of operation and applications of DC machine and Transformers.
CO2	Analyze the performance characteristics of DC machine and transformers.
CO3	Perform/Demonstrate speed control of DC motor.
CO4	Compute the efficiency of DC machine and transformers.
CO5	Identify the parts of transformers and perform maintenance of transformers.

## CO-PO MATRIX OF ENERGY CONVERSION-I

---

CO-PO-PSO MAPPING										
CO	PO1	PO2	PO3	PO4	PO5	PO6	PO7	PSO1	PSO2	PSO3
CO1	3	1	1	0	-	-	-	3	1	1
CO2	3	2	1	0	-	-	-	3	1	1
CO3	3	3	2	0	-	-	-	3	1	1
CO4	3	3	1	0	-	-	-	3	1	1
CO5	3	2	1	1	-	-	-	3	1	1
Average	3	2.2	1.2	0.2				3	1	1

## Th1. ENERGY CONVERSION – I

Name of the Course: Diploma in Electrical Engineering			
Course code:		Semester	4 <sup>th</sup>
Total Period:	75 (60L + 15T)	Examination	3 hrs
Theory periods:	4P / week	Internal Assessment :	20
Tutorial:	1 P / week		
Maximum marks:	100	End Semester examination:	80

### A. RATIONALE

Energy Conversion-I deals with DC machines and transformers. The application of DC generators and motors in modern industries are still in practice. The electrical technicians have to look after the installation, operation, maintenance and control of such machine. So the knowledge of these machines is felt essential. Transformers of various voltage ratios and KVA ratings are in wide use in industries as well as in distribution and transmission.

### B. OBJECTIVES

After completion of this subject the student will be able to:

1. To acquire knowledge of construction, characteristic and control of the DC machines.
2. To acquire knowledge on performance of DC machines and transformers.
3. To acquire knowledge of testing and maintenance of transformers and DC machines.

### C. TOPIC WISE DISTRIBUTION OF PERIODS

Sl. No.	Topic	Periods
1.	DC GENERATORS	17
2.	DC MOTORS	15
3.	SINGLE PHASE TRANSFORMER	20
4.	AUTO TRANSFORMER	03
5.	INSTRUMENT TRANSFORMERS	05
TOTAL		60

### D. COURSE CONTENT IN TERMS OF SPECIFIC OBJECTIVES

#### 1. D.C GENERATOR

- 1.1. Operating principle of generator
- 1.2. Constructional features of DC machine.
  - 1.2.1. Yoke, Pole & field winding, Armature, Commutator.
  - 1.2.2. Armature winding, back pitch, Front pitch, Resultant pitch and commutator- pitch.
  - 1.2.3. Simple Lap and wave winding, Dummy coils.
- 1.3. Different types of D.C. machines (Shunt, Series and Compound)
- 1.4. Derivation of EMF equation of DC generators. (Solve problems)
- 1.5. Losses and efficiency of DC generator. Condition for maximum efficiency and numerical problems.

- 1.6. Armature reaction in D.C. machine
- 1.7. Commutation and methods of improving commutation.
  - 1.7.1. Role of inter poles and compensating winding in commutation.
- 1.8. Characteristics of D.C. Generators
- 1.9. Application of different types of D.C. Generators.
- 1.10. Concept of critical resistance and critical speed of DC shunt generator
- 1.11. Conditions of Build-up of emf of DC generator.
- 1.12. Parallel operation of D.C. Generators.
- 1.13. Uses of D.C generators.

## 2. D. C. MOTORS

- 2.1. Basic working principle of DC motor
- 2.2. Significance of back emf in D.C. Motor.
- 2.3. Voltage equation of D.C. Motor and condition for maximum power output(simple problems)
- 2.4. Derive torque equation (solve problems)
- 2.5. Characteristics of shunt, series and compound motors and their application.
- 2.6. Starting method of shunt, series and compound motors.
- 2.7. Speed control of D.C shunt motors by Flux control method. Armature voltage Control method. Solve problems
- 2.8. Speed control of D.C. series motors by Field Flux control method, Tapped field method and series-parallel method
- 2.9. Determination of efficiency of D.C. Machine by Brake test method(solve numerical problems)
- 2.10. Determination of efficiency of D.C. Machine by Swinburne's Test method(solve numerical problems)
- 2.11. Losses, efficiency and power stages of D.C. motor(solve numerical problems)
- 2.12. Uses of D.C. motors

## 3. SINGLE PHASE TRANSFORMER

- 3.1 Working principle of transformer.
- 3.2 Constructional feature of Transformer.
  - 3.2.1 Arrangement of core & winding in different types of transformer.
  - 3.2.2 Brief ideas about transformer accessories such as conservator, tank, breather, and explosion vent etc.
  - 3.2.3 Explain types of cooling methods
- 3.3 State the procedures for Care and maintenance.
- 3.4 EMF equation of transformer.
- 3.5 Ideal transformer voltage transformation ratio
- 3.6 Operation of Transformer at no load, on load with phasor diagrams.
- 3.7 Equivalent Resistance, Leakage Reactance and Impedance of transformer.
- 3.8 To draw phasor diagram of transformer on load, with winding Resistance and Magnetic leakage with using pf, leading pf and lagging pf load.
- 3.9 To explain Equivalent circuit and solve numerical problems.
- 3.10 Approximate & exact voltage drop calculation of a Transformer.
- 3.11 Regulation of transformer.
- 3.12 Different types of losses in a Transformer. Explain Open circuit and Short Circuit test.(Solve numerical problems)
- 3.13 Explain Efficiency, efficiency at different loads and power factors, condition for maximum efficiency (solve problems)
- 3.14 Explain All Day Efficiency (solve problems)
- 3.15 Determination of load corresponding to Maximum efficiency.
- 3.16 Parallel operation of single phase transformer.

**4. AUTO TRANSFORMER**

- 4.1. Constructional features of Auto transformer.
- 4.2. Working principle of single phase Auto Transformer.
- 4.3. Comparison of Auto transformer with an two winding transformer (saving of Copper).
- 4.4. Uses of Auto transformer.
- 4.5. Explain Tap changer with transformer (on load and off load condition)

**5. INSTRUMENT TRANSFORMERS**

- 1.1 Explain Current Transformer and Potential Transformer
- 1.2 Define Ratio error, Phase angle error, Burden.
- 1.3 Uses of C.T. and P.T.

**Syllabus coverage up to Internal assessment**

Chapters: 1 and 2.

<b>Learning Resources:</b>			
<b>Sl.No</b>	<b>Title of the Book</b>	<b>Name of Author</b>	<b>Publisher</b>
1	<i>Electrical Technology – II</i>	<i>B. L. Thareja and A. K. Thareja</i>	<i>S.Chand</i>
2	<i>A Textbook of Electrical Machines</i>	<i>K R Siddhapura, D B Raval</i>	<i>Vikas</i>
3.	<i>Electrical Technology</i>	<i>J. B. Gupta</i>	<i>S.K.Kataria and Sons</i>
4.	<i>Electric Machine</i>	<i>Ashfaq Husain</i>	<i>Dhanpat Rai and Sons</i>
5.	<i>Electrical Machine</i>	<i>S. K. Bhattacharya</i>	<i>TMH</i>
6.	<i>Electrical Machines</i>	<i>D P Kothari, I J Nagrath</i>	<i>Mc Graw Hill</i>
7	<i>Electrical Machines</i>	<i>Prithwiraj purakait and Indrayudh Bandyopadhyay</i>	<i>OXFORD</i>

# DC GENERATOR

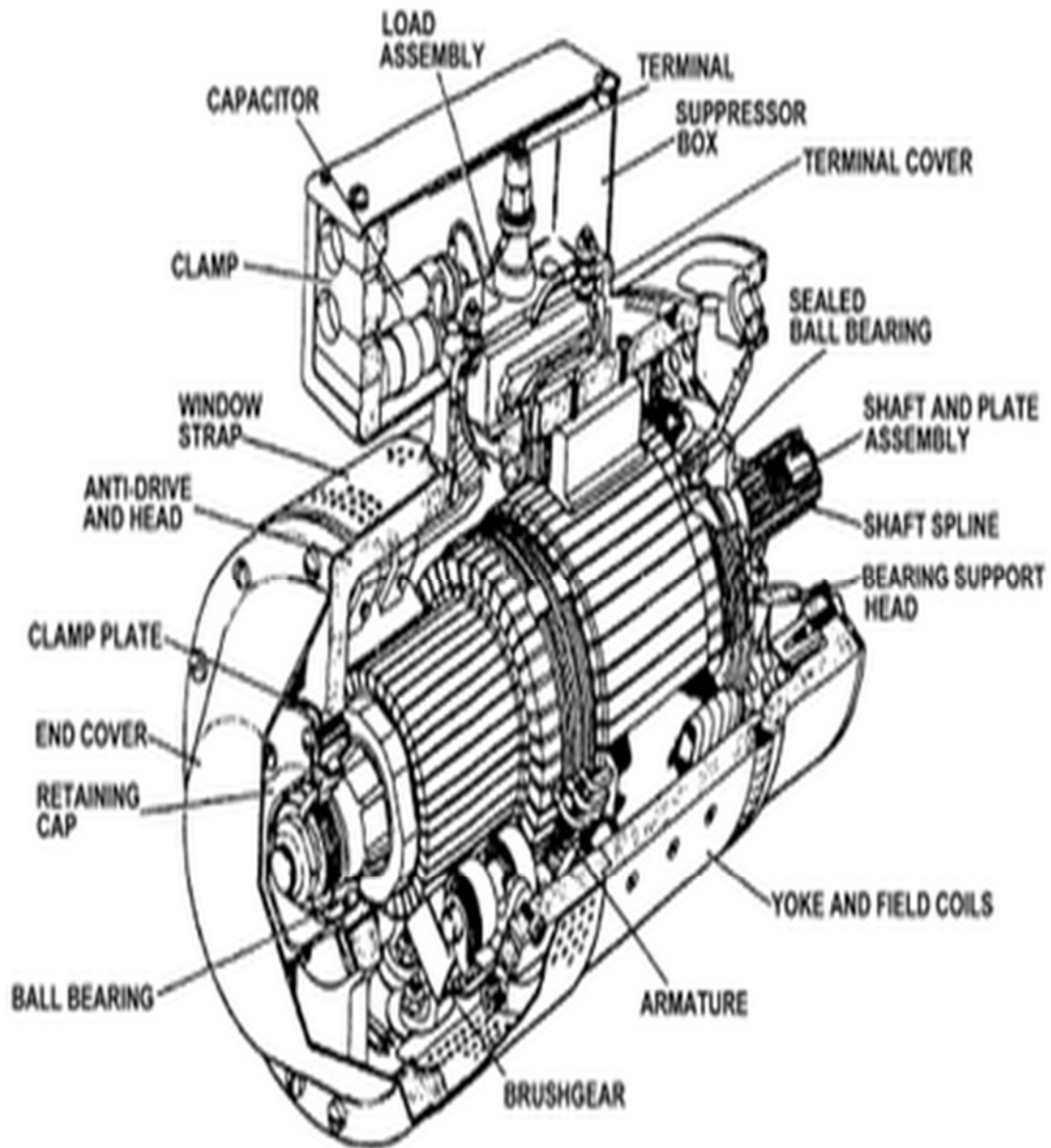

# INTRODUCTION:

It is an electrical machine which converts mechanical energy in to electrical energy .

## CONSTRUCTION OF D.C. GENERATOR

It consist of the following main parts .

- A. YOKE OR MAGNETIC FRAME
- B. POLE CORES AND POLE SHOES
- C. FIELD WINDING
- D. ARMATURE
- E. COMMUTATOR
- F. BRUSH

### Yoke or Magnetic Frame

It is made of cast iron .

It's function is to protect the inner parts of the machine from mechanical injury

It holds the inner parts of the machine .

It will not allow the magnetic flux which is produced in the field poles to go out.

### Pole Cores And Pole Shoes

It is made of laminated silicon steel material . The order of lamination is 0.35mm to 0.5mm . The shape of pole shoes as shown in figure . They spread out the flux on the air gap and also being of larger crossection to reduce the reluctance of the magnetic path . so that the flux produced by the poles will be more...

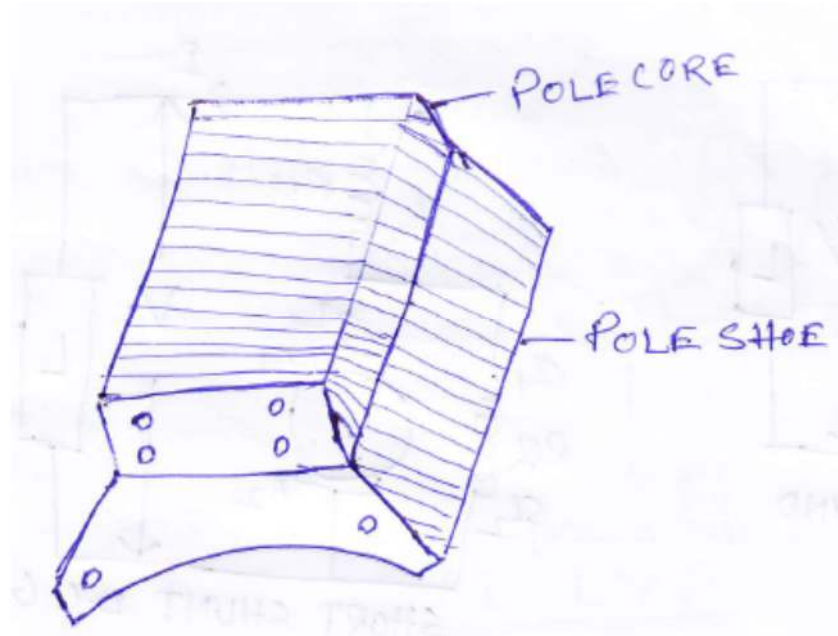

Silicon steel material is used to reduce the hysteresis loss . The support the field coils .

## Field Winding

It consists of thick copper wires wound over the pole cores .

When D.C current passes through than the electromagnetic is converted in to magnet and it will produce necessary magnetic flux .

## Armature

It is the rotating part of the machine .

It is made of laminated silicon steel material in cylindrical shape . The lamination are approximately 0.5mm thick .

There are so many slots in its outer periphery where the armature winding are placed .

## Commutator

It is made of hard-drawn copper material .

It is in cylindrical shape .

The function of commutator is to collect the current from the armature conductor and convert the alternating current which is induced in the armature in to unidirectional D.C current.



The no. of commutator segments is equal to the no. of coils . Each commutator segment is separated from another by the help of mica insulation .

### BRUSH

It is made of carbon due to its (-) ve temperature co-efficient of resistance property .

It slip over the commutator and its function is to collect current from the commutator and supply to the external load circuit .

### WORKING PRINCIPLE

D.C Generator works according to the principle of Faraday's laws of electromagnetic induction .

When ever a conductor cuts the magnetic lines of force an emf is induced in it . Here the mechanical power is utilized to rotate the armature . The armature cut and the magnetic field an emf is induced on the armature conductors . The induced emf is

$$e = -N \frac{d\phi}{dt}$$

### TYPES OF ARMATURE WINDING

There are two types of armature windings .

- A. LAP WINDING
- B. WAVE WINDING

#### LAP WINDING

In case of lap winding the no. of poles is equal to no. of parallel paths . (A=P)

It is used where high current and low voltage is required .

#### WAVE WINDING

In case of wave winding the no. of parallel paths is always equal to two (A=2) .

It is used where high voltage and low current is required .

### EMF EQUATION OF DC GENERATOR

Let P = No of poles

$\phi$  = Flux per pole in weber

$Z$  = Total no. of conductor

$N$  = Speed of armature in r. p.m

$A$  = No. of parallel paths

$\frac{Z}{A}$  = Number of conductors / parallel paths

The emf induced in the armature due to flux linkage in the conductor is given

By  $e = -N \frac{d\phi}{dt}$

Emf induced per conductor

$$e = \frac{d\phi}{dt} \quad (\because N = 1)$$

Now flux cut per conductor in one revolution .  $d\phi = p\phi$

$N$  = Number of rotation per minute .

Number of rotation per second =  $\frac{N}{60}$

Time taken to complete one revolution

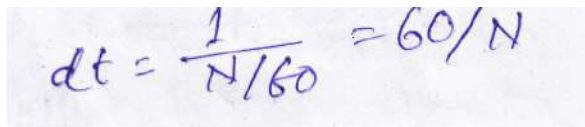
$$dt = \frac{1}{N/60} = 60/N$$

Now emf generated per conductor

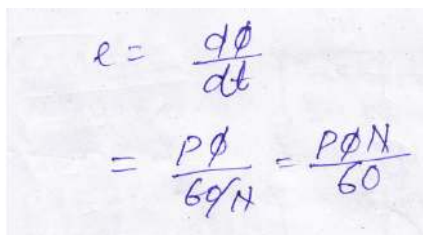
$$e = \frac{d\phi}{dt} \\ = \frac{p\phi}{60/N} = \frac{p\phi N}{60}$$

Emf induced per parallel path

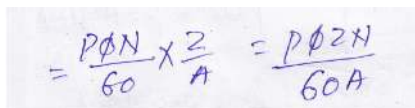
$$= \frac{p\phi N}{60} \times \frac{Z}{A} = \frac{p\phi ZN}{60A}$$

Generated emf ( $E_g$ ) =  $\frac{p\phi ZN}{60A}$

I.e  $E_g = \frac{p\phi ZN}{60A}$

## CLASSIFICATION OF D.C GENERATOR

D.C Generator are classified in to two types according to their excitation .

- A. SEPARATLY-EXCITED D.C GENERATOR
- B. SELF-EXCITED D.C GENERATOR

### SEPARATLY-EXCITED D.C GENERATOR

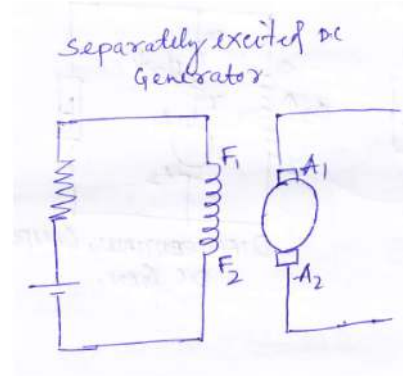

If the

field winding is excited by some external independent dc source then it is known as separately excited D.C generator .

### SELF-EXCITED D.C GENERATOR

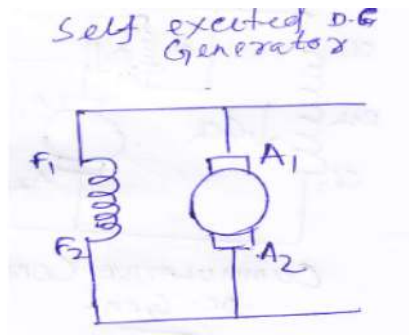

If the field magnets are excited by its own current , then it is known as self excited D.C Generator . It does not require any external source .

According to the connection of the field .

Winding Self-excited generators are classified in to 3 types .

- A. D.C Shunt Generator
- B. D.C Series generator
- C. D.C Compound Generator

## D.C SHUNT GENERATOR

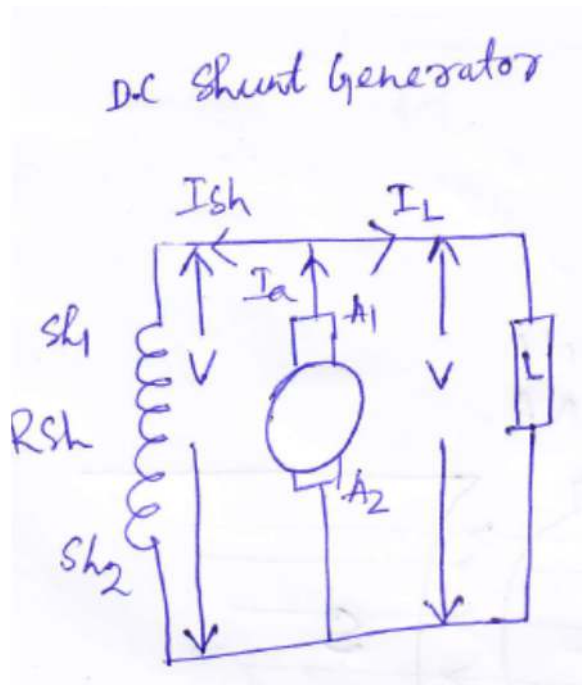

The field winding is connected in parallel with the armature . The field winding is excited by the terminal voltage .

$$I_{sh} = \frac{V}{R_{sh}}$$

Where  $V$  = Terminal voltage or voltage across the load .

$R_{sh}$  = shunt field resistance

$$I_a = I_{sh} + I$$

$$E_g = V + I_a R_a + b.d$$

Where .  $R_a$  = Armature resistance which is very very small .

$I_a R_a$  = Armature Resistance drop

$b.d$  = Brush contact drop

$E_g$  = Generated emf in the armature .

## D.C SERIES GENERATOR

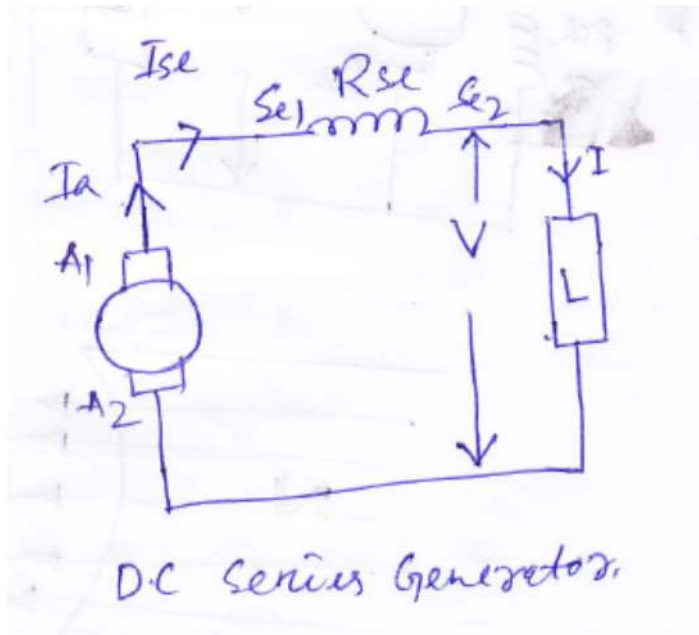

The field winding is connected in series with the armature .

Here  $I_a = I_{sc} = I$

$E_g = V + I_a (R_a + R_{sc})$  b.d

Here the field is excited by the load current .

## D.C COMPOUND GENERATOR

It is the combination of series of field and shunt field .

### LONG-SHUNT COMPOUND GENERATOR

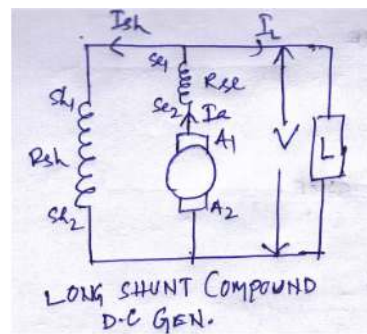

$$I_{sh} = \frac{V}{R_{sh}}$$

$$I_a = I + I_{sh}$$

$$E_g = v + I_a R_a + I_a R_{se} + b.d$$

## SHORT-SHUNT COMPOUND GENERATOR

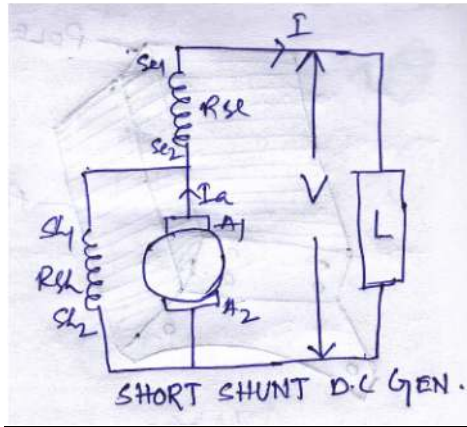

Here  $I_{se} = I$

$$I_{sh} = \frac{V + I_{se}R_{se}}{R_{sh}}$$

$$I_a = I + I_{sh}$$

$$E_g = V + I_a R_a + I R_{se} + b \cdot d$$

- A. Cumulatively Compound dc generator .
- B. Differentially Compound D.C generator .

### LOSSES IN A.D.C MACHINE .

There are 3 types of losses in a D.C machine .

- A. Copper loss =  $I^2 R$
- B. Iron / Core / Magnetic Loss
- C. Mechanical loss

#### COPPER LOSS (30-40%)

The loss occurs due to the resistance . It is about 30-40%

- i. Armature copper loss =  $I_a^2 R_a$
- ii. Series field copper loss =  $I_{se}^2 R_{se}$
- iii. Shunt field copper loss =  $I_{sh}^2 R_{sh}$

#### IRON / CORE / MAGNETIC LOSS (20-30%)

The losses occur in the machine armature and field core .

It consists of

- i. Hysteresis loss =  $W_h = h k B_{max}^{1.6} f V$  wats
- ii. Eddy current loss =  $W_e = k B_{max}^2 f^2 t^2 v$  wats

Where h = steinmertz co-efficient of hysteresis constant .

$B_{max}$  = Max . Flux density in  $wb/m^2$

f = Frequency in HZ

t = Thickness of lamination

V = Volume of material

For reducing hysteresis loss silicon steel material is preferred .

For reducing eddy current loss laminated sheets are used . lamination is done in order to reduce eddy current loss.

### MECHANICAL LOSS (10-20%)

It consists of friction and windage loss of rotating machine . air shunt .

### STRAY LOSS

It is the sum of iron loss and mechanical loss stray loss = Iron loss + Mechanical loss

### CONSTANT LOSS ( $W_c$ )

It is the sum of stray loss and shunt field copper loss .

$$W_c (\text{Constant Loss}) = \text{stray loss} + \text{shunt field copper loss}$$

$$= \text{Iron loss} + \text{mechanical loss} + \text{shunt field copper loss}$$

Since shunt field current is constant the shunt field copper loss is also constant .

### EFFICIENCY OF A D.C MACHINE

Efficiency is defined as the ratio of out put to input of a machine

$$\begin{aligned} \text{Efficiency (h)} &= \frac{\text{out } \Phi_{\text{out}}}{\text{input } \Phi} \\ &= \frac{\text{out } \Phi_{\text{out}}}{\text{out } \Phi_{\text{out}} + \text{loss}} \end{aligned}$$

## CONDITION FOR MAXIMUM EFFICIENCY OF D.C GENERATOR

$$\begin{aligned}\text{Efficiency} &= \frac{O/P}{I/P} = \frac{\text{output}}{\text{output} + \text{losses}} \\ &= \frac{O/P}{I/P + W_c + I a^2 R a} \\ &= \frac{VI}{VI + W_c + I a^2 R} \quad (\because I/a \gg I) \\ &= \frac{VI}{VI + W_c + I^2 R a} \quad (\because I a = I)\end{aligned}$$

The efficiency will be maximum when  $\frac{dh}{dI} = 0$

$$\begin{aligned}\Rightarrow \frac{d}{dI} \left( \frac{VI}{VI + W_c + I^2 R a} \right) &= 0 \\ \Rightarrow \frac{V[VI + W_c + I^2 R a] - VI[v + 2IRa]}{(VI + W_c + I^2 R a)^2} &= 0 \\ \Rightarrow v[VI + W_c + I^2 R a] - v^2 I + 2vIRa &= 0 \\ \Rightarrow v[VI + W_c + I^2 R a] - vI[v + 2IRa] &= 0 \\ \Rightarrow [VI + W_c + I^2 R a] &= I[v + 2IRa] \\ \Rightarrow vI + W_c + I^2 R a &= vI + 2I^2 R a \\ \Rightarrow W_c - I^2 R a + 2I^2 R a & \\ \Rightarrow W_c &= I^2 R a\end{aligned}$$

Efficiency will be maximum when constant loss is equals to variable .

The load current corresponding to maximum efficiency is given by  $I = \sqrt{\frac{W_c}{R a}}$

## ARMATURE REACTION

When current flows through the armature conductors a magnetic field is produced .

This magnetic field due to armature current weakens and distorts the main magnetic field produced by the field poles . This effect is known as armature reaction .



## AT NO-LOAD

The armature current is zero or small volume . This is due to the field flux . The vector of  $m$  represents the MMF producing the main field . Here MNA ( Magnetic Natural Axis ) and GNA ( Geometrical Natural Axis ) are co-incident with each other . The MNA and GNA are perpendicular to field .

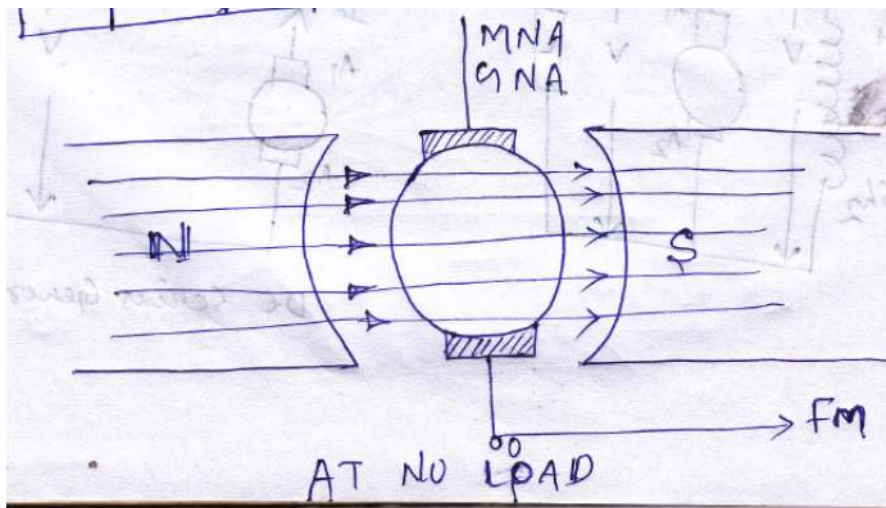

## AT LOAD

When the generator is loaded . It will produce a magnetic field considering only the armature current .

The vector of  $OF_A$  represents both in magnitude and direction of the MMF due to armature winding.

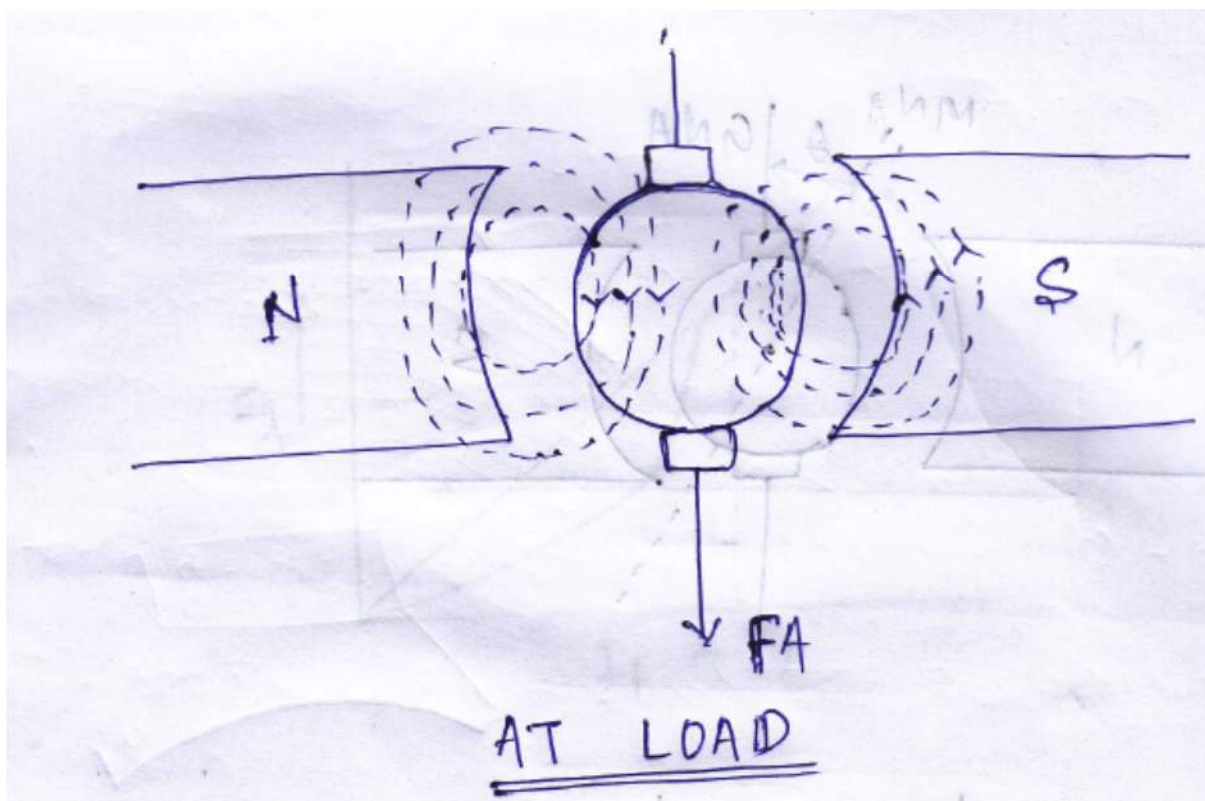

## COMBINING EFFECT

Under actual load condition , the above two effects exists simultancously in the generator .

The flux through the armature ( resultant flux ) is no longer uniform and symmetrical about the pole axis.

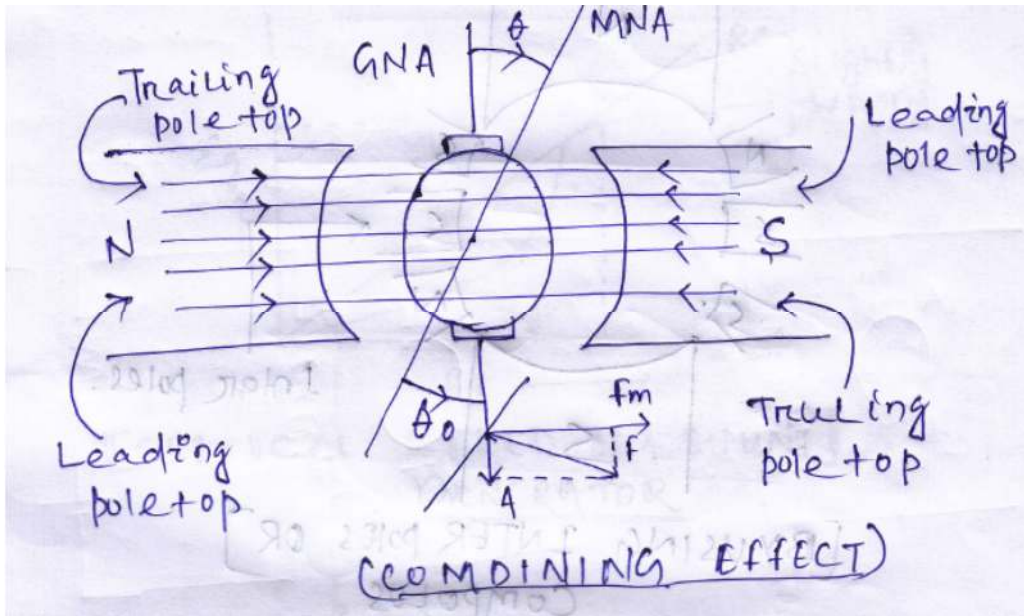

The resultant is  $OF$  , which is the vector sum of  $OF_m$  and  $OF_a$  . The new position of  $MNA$  is displaced from it's original position by an angle , because  $MNA$  is always perpendiculars .

The armature MMF is found to lie in the direction of  $MNA$  .

The armature MMF is now represented by the of  $F_A$  . Which is vertical but is inclined by an angel  $\phi$  to the left . It can now be resolved in to two component.

We find that

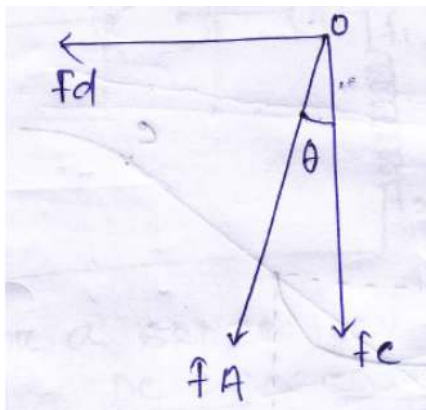

- I. Component OFc is at right angle to the vector OFm representing the main MMF . It produce distortion in main field and is hence called the cross magnetising or distorting component of the armature reaction .
- II. The component OFd is in direct opposition to OFm which represent the main MMF . It exerts a demagnetizing influence on the main pole flux . It is the demagnetizing component of the armature reaction which weakens the main flux .
- III. IN CASE OF MOTOR

When the machine act as motor . The current direction is reversed and hence MNA is shifted by an angle  $\alpha$  in the backward direction.

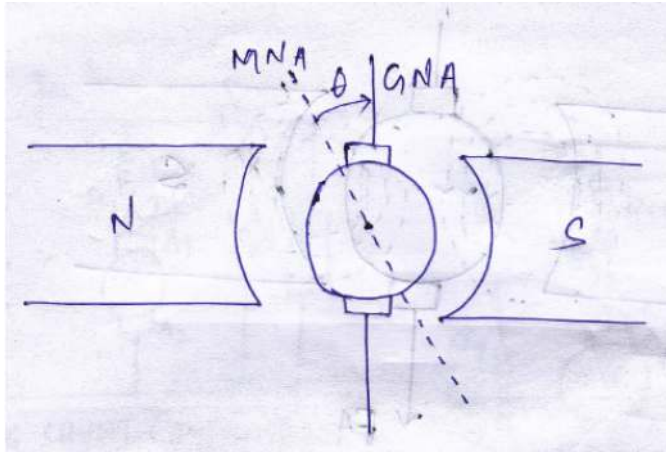

### DEMAGNETISING AMPERE TURN

Let  $Z$  = Total Number of armature conduction

$I$  = Armature current

$\phi m$  = Mechanical degree in forward movment .

Total no. of armature conduction in angle

$$\angle AOB \text{ and } \angle BOD = \frac{Z}{360} \times 4\phi m$$

$$\text{No. of turn under LAOC and LBOD} = \frac{Z}{360} \times 2\phi m \text{ ( } \therefore \text{ two conduction constitute one turn )}$$

$$\text{Demagnetizing ampere turns per pair of poles} = \frac{ZI}{360} \times 2\phi m$$

$$\text{Demagnetizing ampere turns per pole} = \frac{ZI}{360} \times \phi m$$

## CROSS MAGNETISING AMPERE TURN

Total no of conductors per pole =  $\frac{Z}{P}$

Help Demagnetizing conductors per pole =  $\frac{ZI}{360} \times 2\phi_m$

Cross magnetizing conductors pole = Total no of conductors per pole

$$= \frac{Z}{P} - \frac{Z}{360} \times \frac{2\phi_m}{360}$$

$$= Z \left( \frac{1}{P} - \frac{2\phi_m}{360} \right)$$

Cross magnetizing Ampere turns per pole

$$= \frac{Z}{P} - \frac{Z}{360} \times \frac{2\phi_m}{360}$$

$$= Z \left( \frac{1}{P} - \frac{2\phi_m}{360} \right)$$

$$\phi_{\text{mech}} = \frac{\phi_{\text{elect}}}{\text{Pair of Poles}} \quad (\text{If the angle is given in electrical degrees})$$

## COMMUTATION

The emf induced in the armature conductors of a machine is an alternating in nature. The current in a conductor flows in one direction when it is under north pole and in reverse direction when it is under south pole.

The reversal of current of current from (+) I to (-)I has to occur when two commutator segments to which the armature coil is connected are short circuited by a brush. This process is known as commutation period. The current in the coil has to reach its full value when in the reversed direction at the end of commutation period. If this does not happen the difference of current would pass from commutator to brush in the form of an A.C. arc. This arcing causes sparking pitting and roughing of the commutator surface.

Two major effects of disturb the commutation process are armature reaction and reactance voltage. The armature reaction causes a shift of the M.N.P (Magnetic Neutral Plane) in the forward direction for the generator and in the back direction for the motors. For proper commutation in the commutator brush should short-circuited.

The commutator segments at the instants when voltage across them is zero. Because of the shift of M.N.P, the voltage between the segments has a finite value of the brush are in the G.N.P. The result is a current flowing between the short circuited commutator segments and arcing. The shifting of brushes the new M.N.P depends on the magnitude of load current. Greater this current greater is the needed shifting.

greater is the load current since it is practically impossible to shift the brushes every time as the load current changes the brushes are always kept in G.N.P .

In the end the commutation problem is due to the reactance voltage . The time of commutation is very short if a machine is running at 1000 R.P.M. and has 50 commutator segment then is segment moves under a brush and clears it again in time of 0.0012 and seconds . If the current changes from (+) 100A to(-)100A the rate of change of current is  $\frac{dI}{dt}$  .  $\frac{dI}{dt} = 166667$  amp/ sec rate of changes of current is  $\frac{dI}{dt}$  .

The coil under going commutation has an inductance therefore induced emf  $L \frac{dI}{dt}$  is set up in the coil . Through the magnitude of inductance of very high and therefore the magnitude of induced emf coil be appreciable . This EMF is known as reactance voltage and oppose the reversal of current . Thus sparking occurs at the brushes .

Commutation problem can be minimized by different method .

- i. Emf commutation
- ii. By using interpoles
- iii. By resistance commutation
- iv. By using compensating winding

#### By Emf Commutation

In this method a voltage which cancels the reactance voltage is used to ensure good commutation . One way to cancel the reactance voltage is by shifting the brush a little further then the M.N.P . so that they lie in the fringe of the field of the next pole . The Emf induced in the coil opposes the reactance voltage and opposes forces the reversal of current in the coil . However this method is not used because the extend of shifting of brushes depends on the load current and it is not practicable to shift the brushes every time as the load current changes .

#### By Using Interpoles Or Compoles

The interpoles helps on reducing the sparking due to commutation problem of current from A.C to D.C . They are small poles fixed to the yoke and placed in between to main poles . The windings of these poles has few turns of thick copper wire and is connected in series with the armature ckt . There fore the mmf of an interpole is proportional to armature current . The function of interpole is to .

- i. Ensure automatic neutrallization of reactance voltage .
- ii. Cancellation of cross-magnetization effect of armature reaction

# Reactance Commutation

The next approach to achieve two commutation by the use of brushes with high contact resistance then the brushes made from other materials. Hence carbon is used as a brush universally . Also carbon has (-) ve temperature co-efficient of resistance properly .

## Compensating Winding

In order to neutralisation the cross magnetizing effect , compensating winding are used . It is used only in case of large machine . These windings are ambeded in slots in the pole shoes in series with armature in such a way that the current in them flows in opposite direction to that of in the armature induction directly below the poles-shoes .

$$\begin{aligned}\text{No. of compensating winding appear turns per pole} &= \frac{0.7 \times ZI}{2P} \\ &= \frac{0.7 \times Z}{2P}\end{aligned}$$

### DUMMY COILS

When a machine has a wave winding is very necessary to use extra coils to maintains the mechanical balance of the armature . This coil is completely insulated from the remaining winding and it is used for only mechanical balance .

It is known as dummy coils

$$Y_c = \frac{2(C \pm 1)}{P}$$

$Y_c = \frac{Z \pm 2}{P}$	C = No. of coils
---------------------------	------------------

$Y_c$  = Commutator pitch

P = No. of poles

## EQUALLISER RING

The existence of many parallel path in a lap winding leads to be serious problems of circulating currents . The fluxes from all the poles are not exactly equal because of wear and tear on the bearing, the air gap doesnot remain uniform around the whole periphery . As the armature conductor rotates the voltages induce in different parallel paths will be slightly different . Hence armature winding . Due to circulating current energy loss and heating effect results . Therefore equalizer rings are necessary which will be connected to make some potential different parallel path . Each rings are insulated from which others . By using equalizer rings induced emf can be made equal no. of equalizer rings

$$\begin{aligned} &= \frac{\text{Total No. of Conductors}}{\text{N. of Pair of Poles}} \\ &= \frac{Z}{\frac{P}{2}} \\ &= \frac{2Z}{P} \quad (\because \text{No. of Equalliser Rings} = \frac{2Z}{P}). \end{aligned}$$

## CRITICAL FIELD RESISTANCE OF A SHUNT GENERATOR

The maximum emf generated is  $o_c$  ,if the shunt field resistance is increased, then the maximum generated emf is represented by  $o_c$  . so that if becomes a tanjent to the curve . the value of field resistance corresponding to the point of intersection of the field resistance for a given speed again it is seen that ,if the field resistance is increased further beyond the critical ristance the generator does not excite at all in other words the critical field resistance  $R_c$  of a shunt generator is the maximum value of field resistance beyond which the generator can't build of voltage .

## CRITICAL SPEED OF A SHUNT GENERATOR

The speed for which a given shunt field resistance acts as critical field resistance is known as critical speed .

If  $E_1$  and  $E_2$  be the respective values indused emf for the same excitation current at speed  $N_1$  and  $N_2$

$$\text{Then } \frac{E_1}{E_2} = \frac{N_1}{N_2}$$

## CHARACTERISTICS OF D.C GENERATOR

There are three different types of characteristic

(1)-NO-load /magnetization/ open circuit characteristics (o.c.c)

(2)-Internal characteristics

(3)-Load/External characteristics

## (1)-NO LOAD/MAGNETISATION/OPEN CIRCUIT CHARACTERISTICS(O.C.C)

It is graphical relationship between generated emf and field current ( $E_g \sim I_f$ )

### FOR A SEPARATELY EXCITED D.C GENERATOR

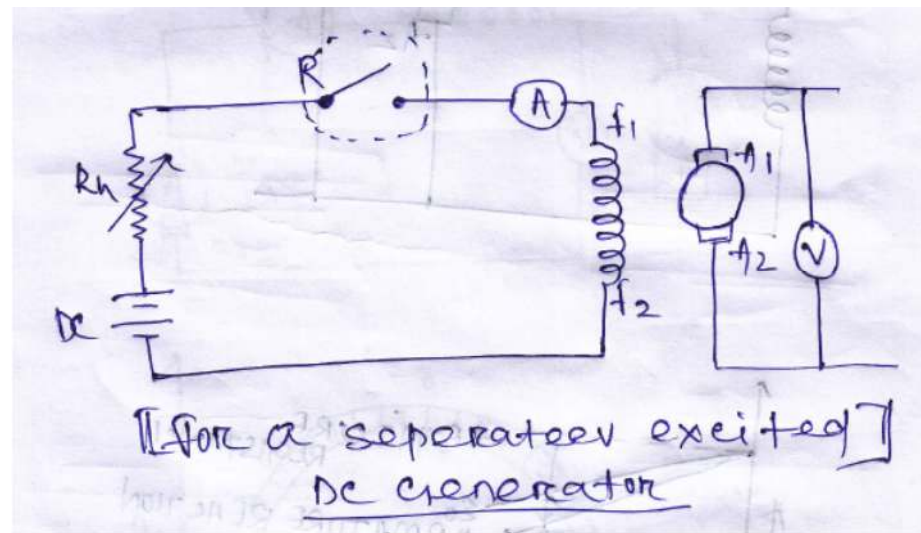

Let the switch is open, but the generator is driven by some external source (Prime-mover or dc motor). It is seen that the generated emf is zero, since

Now the switch is closed and the field current increases gradually. It is seen that as the field current increases, the generated emf is proportional to the field flux. This will continue till saturation. After saturation of magnet field, the field current may be increased but the field flux remains constant. So the generated emf remains constant even if the field current increases.

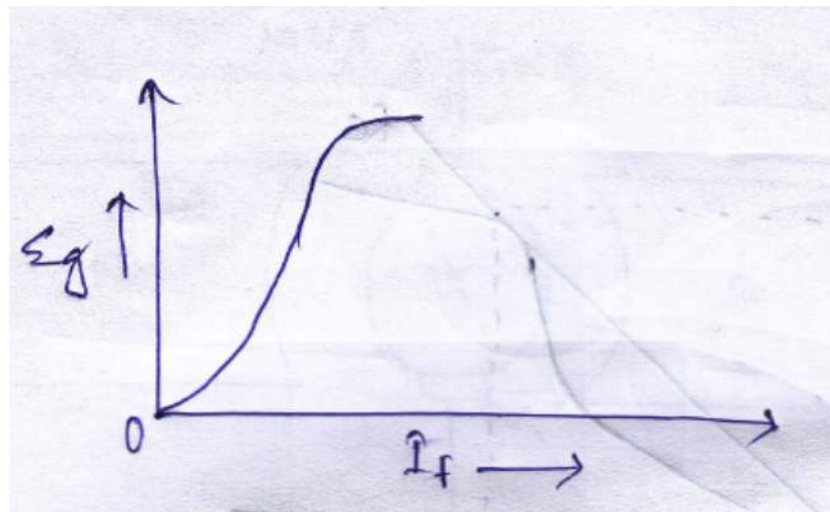



# FOR SELF-EXCITED DC GENERATOR

When the field current is zero, the EMF induced in the armature is 'OA'. This is due to the presence of residual magnetization. Again if the field current increases the EMF increase and it will continue up to the point of saturation. After saturation the field current may increases but field flux remain constant . So that EMF induced will remain constant .

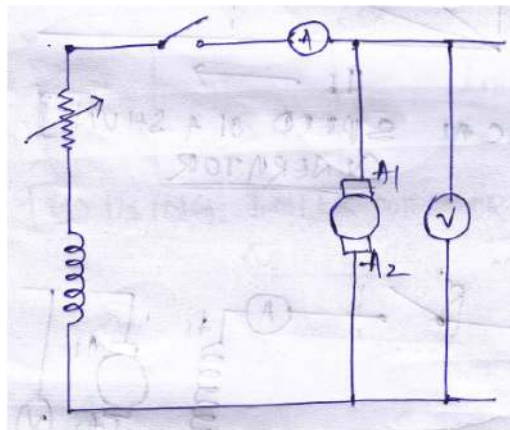
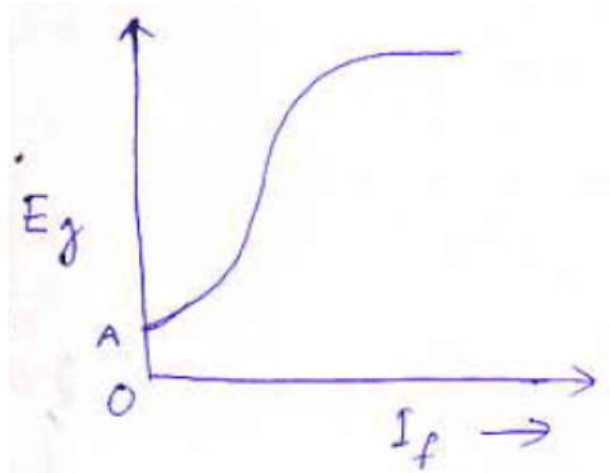

## (2). INTERNAL CHARACTERISTICS:-

It is the graphical relationship between voltage and armature current  $E_0 \approx I_a$  .when the armature current is zero, the generated EMF is equal to the no load voltage. As the armature current increase the armature resistance drop is  $(I_a R_a \text{ drop})$  increases. So the terminal voltage decreases. At heavy loads, due to armature reaction the terminal voltage decreases to a lower value.

We know that,

$$E_g = V + I_a R_a$$

$$V = E_g - I_a R_a$$

### (3) EXTERNAL/LOAD CHARACTERISTICS :- (V ~ I)

It is the graphical relationship between the two terminal voltage and the load current .

$$V \sim I$$

### FOR SHUNT GENERATOR

It is seen that when the load current increase, the terminal voltage decreases. As the load current increase  $I_a R_a$  drop increases .

But at point 'A' if further the load increases, the terminal voltage decreases suddenly.

This is due to the armature reaction .

$$V = E_g - I_a R_a$$

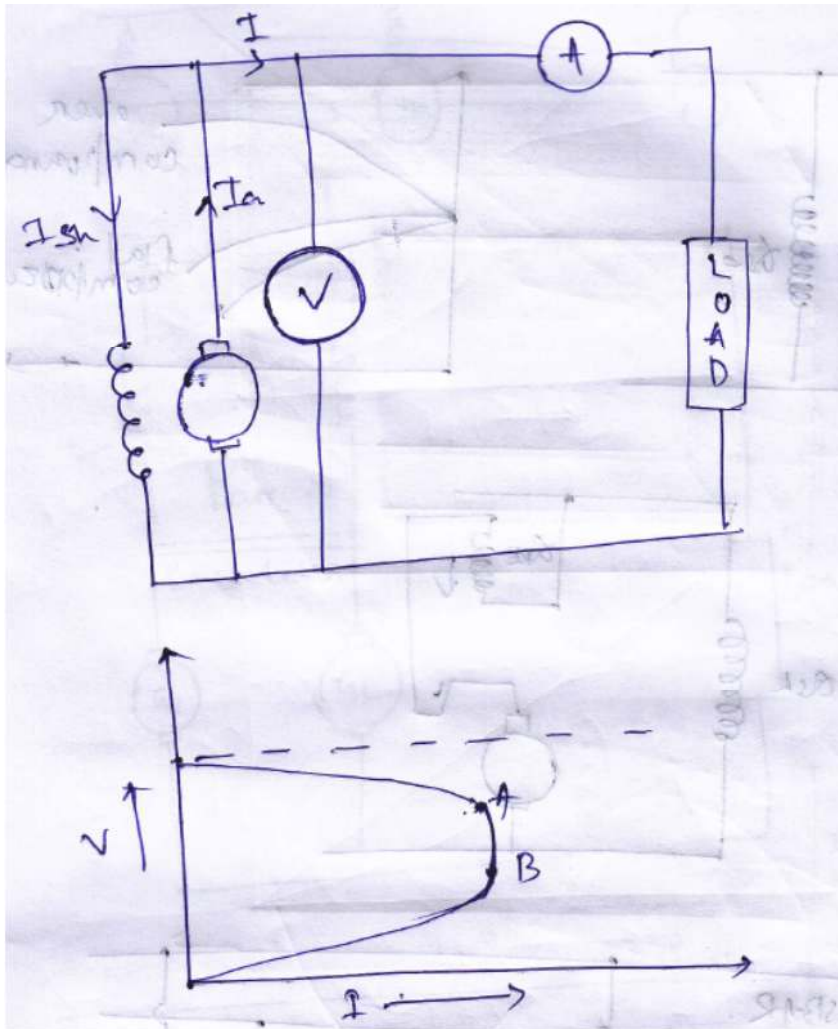

The drops are due to,

- (1) Armature resistance drop ( $I_a R_a$  drop)
- (2) Armature reaction
- (3) The combining effect, the terminal voltage decreases suddenly as the load current increase, it is represented by A to B.

If further the load increases, the generator will come to its instability condition, which is shown by dotted lines. If the load increases further the terminal voltage decreases to a very lower value and the generator cannot maintain its stability. Automatically it will come to 'OFF' position.

This is known as drooping characteristic of D.C shunt generator. Due to this reason it is suitable for lighting purpose and battery charging purpose.

## FOR SERIES GENERATOR:-

It is seen that load current increases the terminal voltage increases. This is due to the load current passes through the field. It continues up to the point of saturation. After saturation, if the load current increases, then the terminal voltage decreases. This is known as rising characteristics of a D.C series generator so it is used as a booster.

$$V = E_g - I_a R_a - I_a R_{se}$$

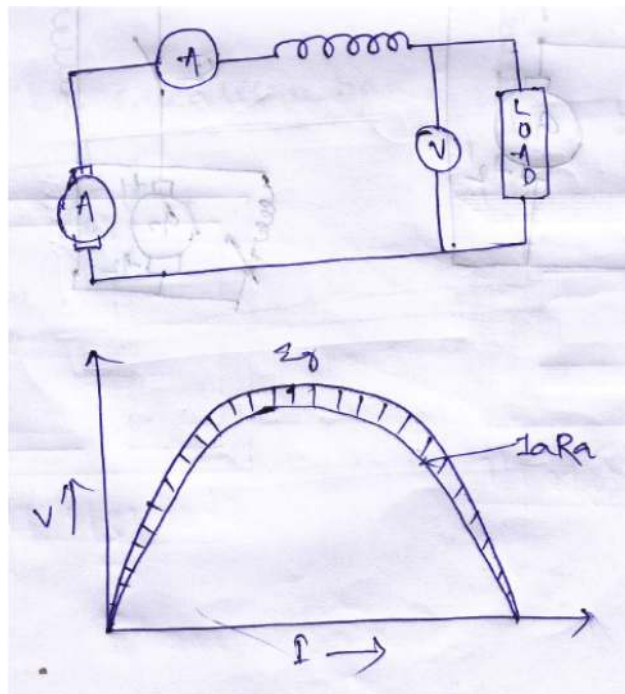

Curve.....

The drops are due to

- (1)  $I_a R_a$  drop
- (2)  $I_a R_{se}$  drop
- (3) Armature Reaction

## FOR COMPOUND GENERATOR:-

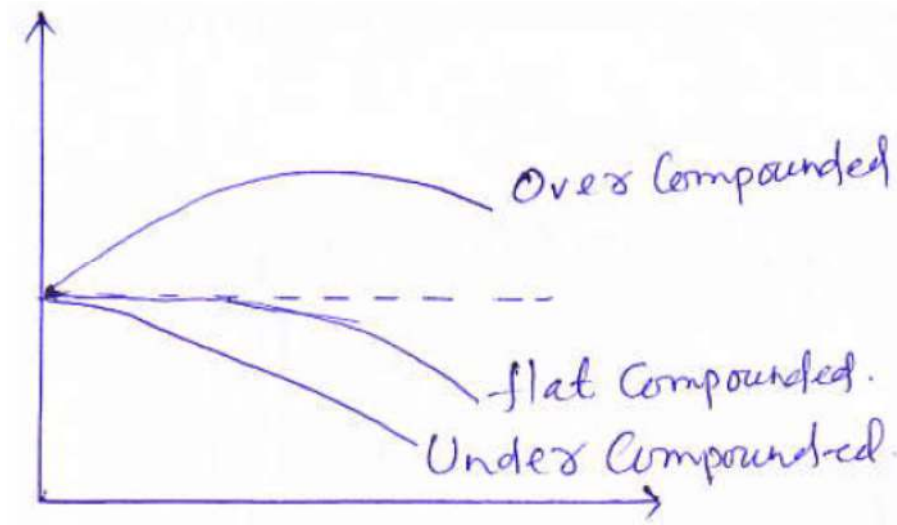
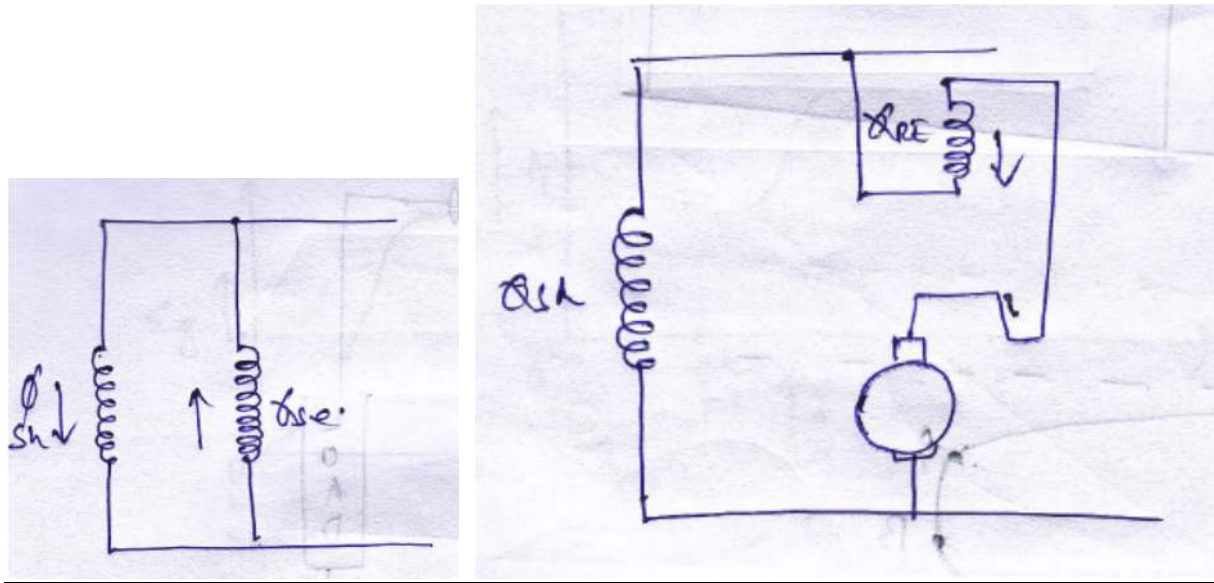

Differential Compound D.C generator Net Phase =  $\phi_{sh} - \phi_{sc}$

Commulatively Compound D.C Generator Net Phase =  $\phi_{sh} + \phi_{sc}$

## OVER COMPOUND/COMMULATIVELY

### COMPOUND:-

In case of commulatively compounded D.C Generator the series field flux aids to the shunt field flux. As the load current increases series field flux increases. As the load current increases, the terminal voltage increases. If the terminal voltage is more than the no load voltage then it is known as over compounded D.C Generator.

## UNDER COMPOUNDED/DIFFERENTILLY

### COMPOUNDED:-

In case of defferentially compounded D.C Generator the series field flux opposes the shunt flux. As the load current increases, the net flux decreases. Hence generated EMF decreases. As the load current increases the terminal voltage decreases, then no load voltage as the load current increases. It is known as external characteristics of under compounded D.C Generator.

### FLAT COMPOUNDED:-

The change in no load voltage to full load voltage is negligible is known as flat compounded D.C Generator. As the load current increases, the terminal voltage decreases slightly.

## CONDUCTION FOR BUILT UP A SELF-EXCITED

### D.C GENERATOR:-

- \*There must be some residual magnetism in the poles.
- \*For the given direction of rotation, the shunt field poles should be connected properly to the armature.
- \*If excited on open circuit, its shunt field resistance should be less than the critical resistance.
- \*If excited on load, then the shunt field resistance should be more than a certain minimum value of resistance which is given by internal characteristics.
- \*The series generator should be started with load.

# PARALLEL OPERATION OF A DC GENERATOR

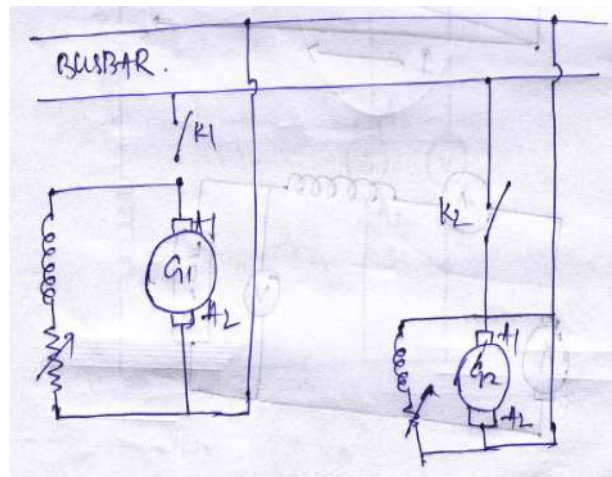

## CONDITION FOR PARALLEL OPERATION

- I. Polarity must be maintained.
- II. The terminal voltage of generator must be equal to the bus bar voltage  $V_1 = V_2 = V$
- III. The load sharing should be equal.

### LOAD EQUAL

Load sharing two generators which have unequal no-load voltage.

Let,  $E_1$  = No load voltage of  $G_1$

$E_2$  = No load voltage of  $G_2$  [?????]

$R_{a1}$  = Armature resistance of  $G_1$

$R_{a2}$  = Armature resistance of  $G_2$

$V$  = Bus bar voltage

= Common terminal voltage

$$\Rightarrow I_{a1} = \frac{E_1 - V}{R_{a1}}$$

$$\Rightarrow I_{a2} = \frac{E_2 - V}{R_{a2}}$$

$$\Rightarrow \frac{I_{a2}}{I_{a1}} = \frac{E_2 - V}{E_1 - V} \cdot \frac{R_{a1}}{R_{a2}}$$

[?]

$$\Rightarrow \frac{K_2 N_2 \phi_2 - V}{K_1 N_1 \phi_1 - V} * \frac{R_{a1}}{R_{a2}}$$

From the above equation it is seen that the bus bar voltage can be kept constant by increasing  $\phi_2$  or  $N_2$  or by reducing  $N_1$  and  $\phi_1$ .

$N_1$  and  $N_2$  are changed by the help of resulting shunt field resistance .

- Two parallel shunt Generator having equal no-load voltage share the load in a ratio that the load current of each machine produces the same drop in each generator .
- In case of 2 generator having un-equal no-load voltage ,the load current produces sufficient voltage drop in each .so as kept their terminal voltage same .

## SERIES GENERATOR IN PARALLEL

Suppose  $E_1$  and  $E_2$  are initially equal generators, supply equal current and have equal series resistance .suppose  $E_1$  increases slightly . so that  $\frac{E_1}{E_2}$

In this case  $I_1$  becomes greater than  $I_2$  .Now the field of machine  $G_1$  is stronger than .Then increases  $E_1$  further the field of machine  $G_1$  is weakened .

Then decreases  $E_2$  further a final stage is reached , when the machine  $G_1$  is supplied not only the whole load but also power to the machine  $G_1$  which starts remaining as a motor .This can be prevented by using equal bus bar machines pass approximately equal currents to the load.

It is essential that series field resistances are inversely proportional to the generator rating .

## COMPOUND GENERATOR IN PARALLEL

It is same as in series Generator for maintaining division of load from no- load to full-load .

- I. The regulation of each generator is same
- II. The series field resistance are inversely proportional to the generator rating .



# Generator

1. A short shunt compound DC generator delivers a load current of 30 A at 220 V, and has armature, series field, and shunt field resistance of  $0.05 \Omega$ ,  $0.30 \Omega$  and  $200 \Omega$  respectively. Calculate the induced emf ~~current~~ and armature current. Allow 1.0 V per brush for contact drop.

Sol<sup>n</sup>

Given data:

$$I = 30 \text{ A}$$

$$V = 220 \text{ V}$$

$$r_a = 0.05 \Omega$$

$$R_{se} = 0.30 \Omega$$

$$R_{sh} = 200 \Omega$$

$$I_a = ?$$

$$E_g = ?$$

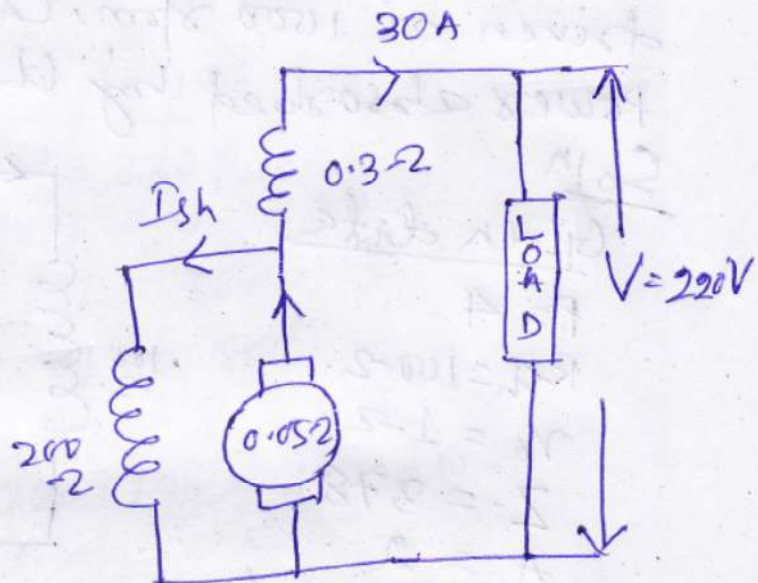

Shunt field Voltage drop =  
V + series field drop

$$= 220 + I \times 0.03$$

$$= 220 + 30 \times 0.03 = 229 \text{ V}$$

$$I_{sh} = \frac{220}{200} = \frac{229}{200} = 1.145 \text{ A}$$

$$I_a = I + I_{sh} = 30 + 1.145 = 31.145 \text{ A}$$

$$E_g = V + I R_{se} + I_a r_a$$

$$= 220 + 30 \times 0.03 + 31.145 \times 0.05$$



2. A 4-pole, d.c. shunt generator with a shunt field resistance of  $100\ \Omega$  and an armature resistance of  $1\ \Omega$  has 378 wave-connected conductors in its armature. The flux per pole is  $0.02\ \text{wb}$ . If a load resistance of  $10\ \Omega$  is connected across the armature terminals and the generator is driven at  $1000\ \text{rpm}$ , calculate the power absorbed by the load.

Soln

Given data

$$P = 4$$

$$R_{sh} = 100\ \Omega$$

$$r_a = 1\ \Omega$$

$$Z = 378$$

$$A = 2$$

$$\phi = 0.02\ \text{wb}$$

$$R_L = 10\ \Omega$$

$$N = 1000\ \text{rpm}$$

$$E_g = \frac{P\phi ZN}{60A} = \frac{4 \times 0.02 \times 378 \times 1000}{60 \times 2}$$

$$= 252\ \text{V}$$

$V$  is the terminal voltage.

$$I_a = \frac{V}{10}, \quad I_{sh} = \frac{V}{100}\ \text{A}$$

$$\text{Armature Current} = \frac{V}{10} + \frac{V}{100}$$

$$= \frac{11V}{100}$$

$$V = E_g - \text{armature drop}$$

$$V = 227\ \text{V}$$

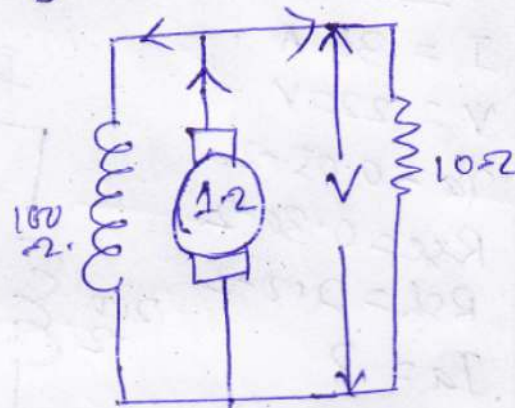

# DC MOTOR

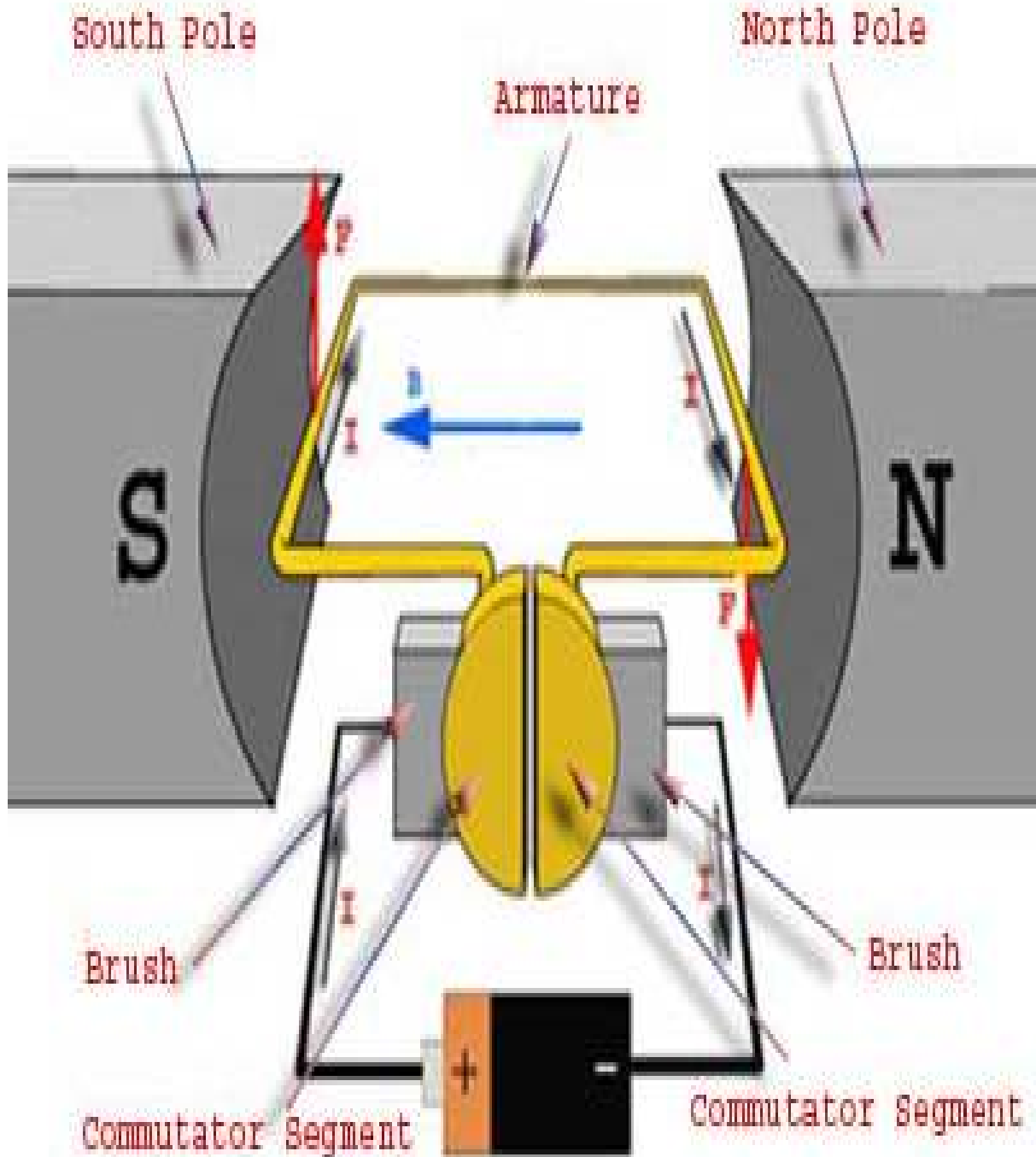

# INTRODUCTION:

Definition : It is an electrical machine which converts electrical energy to mechanical energy .

A D.C. machine is similar in construction to a D.C. generator .The same D.C. machine can be employed as a generator or a motor depending upon the use .

WORKING PRINCIPLE:-

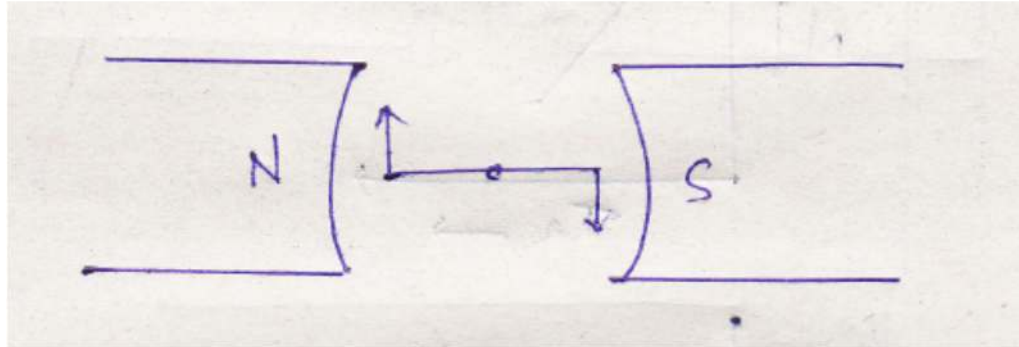

It works on the principle of that when ever a current carrying conductor is placed in side a magnetic field ,it experiences a mechanical force tending to rotate the conductor .

If force experienced by the conductor under the influence of N-pole is upward , then the force under the influence S-pole will be downward . These two equal and opposite force will produce a torque since the two forces are acting on a common conductor and the line of axis .Production of torque ,the conductor starts rotating .

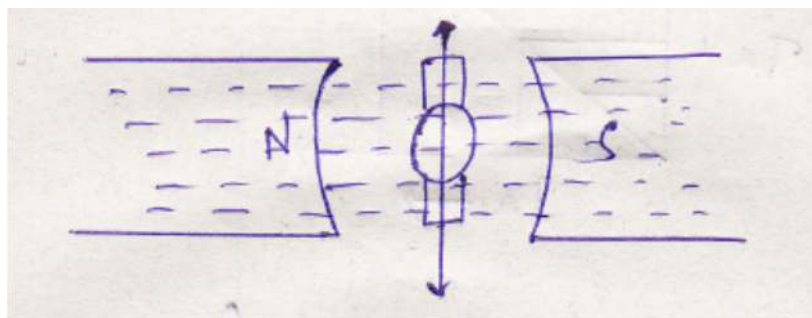



# SIGNIFICANCE OF BACK EMF

When the armature inside the magnet field rotates, the conductors placed in the slots of armature cuts the magnetic flux and hence an emf is induced in it. This induced emf is known as back EMF. Its direction is opposite to the applied emf.

Applying KVL

$$V - E_b - I_a R_a - b'd = 0$$

$$\Rightarrow I_a R_a = V - E_b \text{ (neglecting brush drop)}$$

$$\Rightarrow I_a = \frac{V - E_b}{R_a} = \frac{\text{net voltage}}{\text{Armature resistance}}$$

where,  $E_b$  = back emf

$$E_b = \frac{P \Phi Z N}{60 A}$$

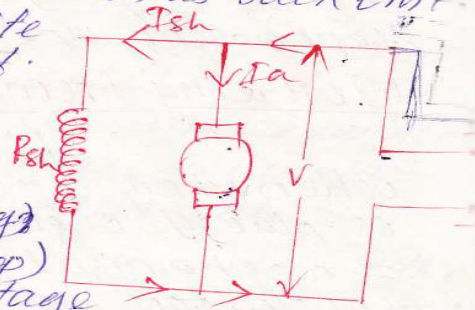

## VOLTAGE EQUATION OF A DC MOTOR!

Armature current  $I_a = \frac{V - E_b}{R_a}$

$$\Rightarrow I_a R_a = V - E_b$$

$$\Rightarrow V = E_b + I_a R_a$$

$$\Rightarrow E_b = V - I_a R_a$$

$V = E_b + I_a R_a$  voltage equation of motor.

Multiplying  $I_a$  in both sides we get

$$V I_a = E_b I_a + I_a^2 R_a$$

where,  $V I_a$  = input to armature

$I_a^2 R_a$  = Armature copper loss

$E_b I_a$  = electrical equivalent of mechanical power known as *opp* of the motor.

## CONDITION FOR MAXIMUM OUTPUT!

The mechanical power developed for motor is  $P_m = E_b I_a = V I_a - I_a^2 R_a$

$$\frac{dP_m}{dI_a} = 0$$

$$\Rightarrow \frac{d}{dI_a} (V I_a - I_a^2 R_a) = 0$$

$$\Rightarrow V - 2I_a R_a = 0$$

$$\Rightarrow V = 2I_a R_a \Rightarrow \frac{V}{2} = I_a R_a$$

where  $\epsilon_b$

We know that  $\epsilon_b = V - I_a R_a$

$$\Rightarrow \epsilon_b = V - \frac{V}{2} = \frac{V}{2}$$

$$\Rightarrow \boxed{\epsilon_b = \frac{V}{2}} \rightarrow \text{condition for maximum power output}$$

### TORQUE EQUATION :

The turning or twisting movement of a force about an axis is known as torque.

$$T = F \times r = \text{Newton} \cdot \text{meter}$$

Work done in one revolution

$$W \cdot D = F \times 2\pi r \text{ joule}$$

Let,  $n = \text{no. of rotation per second}$

$$\text{power developed} = F \times 2\pi r \times n \text{ J/sec}$$

$$= (F \times r) \times 2\pi n \text{ J/sec} = \text{Watts}$$

If  $T_a = \text{armature torque}$  then power =  $\omega T_a \text{ watt}$

where  $\omega = 2\pi n = \text{angular velocity}$

Electrical power converted into mechanical power in the armature  $\epsilon_b I_a = 2\pi n T_a$

$$\Rightarrow T_a = \frac{P \phi Z N}{60 A} \times \frac{I_a}{2\pi N/60} \quad (N \text{ in rpm})$$

$$= \frac{P \phi Z I_a}{2\pi A} = \frac{1}{2\pi} \phi I_a z \left(\frac{P}{A}\right)$$

$$\Rightarrow T_a = 0.159 \phi I_a z \left(\frac{P}{A}\right) \text{ N} \cdot \text{m} = 9.55 \frac{\epsilon_b I_a}{N} \text{ (N in rpm)}$$

$$\text{ie } T_a = k \phi I_a$$

$$\text{where } k = 0.159 z \left(\frac{P}{A}\right) = \text{constant}$$

$T_a \propto \phi_a$  (for shunt motor since "  $\phi$  " is constant)

$T_a \propto I_a^2$  (for series motor since "  $\phi \propto I_a$  ")

$$T_{a1} = K \phi_1 I_{a1}$$

$$T_{a2} = K \phi_2 I_{a2}$$

$$\Rightarrow \frac{T_{a2}}{T_{a1}} = \frac{K \phi_2 I_{a2}}{K \phi_1 I_{a1}}$$

$$\Rightarrow \frac{T_{a2}}{T_{a1}} = \frac{I_{a2}}{I_{a1}} \text{ (for shunt motor " } \phi \text{ " is constant)}$$

$$\Rightarrow \frac{T_{a2}}{T_{a1}} = \frac{I_{a2}^2}{I_{a1}^2} \text{ (for series motor " } \phi \propto I_a \text{ )}$$

## SPEED EQUATION

$$E_b = \frac{P \phi Z N}{60 A}$$

$$\Rightarrow N = \frac{60 A E_b}{P \phi Z}$$

$$\Rightarrow N = K \frac{E_b}{\phi} \text{ (where } K = \frac{60}{P Z} \text{ i.e. constant)}$$

$$\Rightarrow N \propto \frac{E_b}{\phi}$$

$$\Rightarrow N \propto E_b \text{ (for shunt motor)}$$

$$\Rightarrow N \propto V I_a R_a$$

**Again**  $N = \frac{E_b}{\phi}$

$$\Rightarrow N \propto \frac{1}{\phi} \text{ (If } E_b \text{ is constant)}$$

$$\Rightarrow N \propto \frac{1}{f}$$

# FOR SHUNT MOTOR

$N_1$  = speed of the 1st case

$I_{a1}$  = Armature current in 1<sup>st</sup> case

$\phi_1$  = flux /oppose in 1<sup>st</sup> case

$N_2$  = speed of the 2<sup>nd</sup> case

$I_{a2}$  = Armature current in 2<sup>nd</sup> case

$\phi_2$  = flux /oppose in 2<sup>nd</sup> case

$$E_{b1} = \frac{P\phi_1ZN_1}{60A}$$

$$E_{b2} = \frac{P\phi_2ZN_2}{60A}$$

$$N_1 = K \frac{E_{b1}}{\phi_1}$$

$$N_2 = K \frac{E_{b2}}{\phi_2} \quad (\text{Where } K = \frac{60A}{PZ} \text{ is constant})$$

$$\therefore \frac{N_2}{N_1} = \frac{K \frac{E_{b2}}{\phi_2}}{K \frac{E_{b1}}{\phi_1}}$$

$$\frac{E_{b2} * \phi_1}{E_{b1} \phi_2}$$

$\frac{N_2}{N_1} = \frac{E_{b2}}{E_{b1}}$
---

( $\because$  sine  $\phi_1 = \phi_2 = \phi$  )

# FOR SERIES MOTOR

$$\frac{N_2}{N_1} = \frac{\epsilon_{b2} * \phi_1}{\epsilon_{b1} * \phi_2}$$
$$\Rightarrow \frac{N_2}{N_1} = \frac{\epsilon_{b2} * I_{a1}}{\epsilon_{b1} * I_{a2}}$$

## SHAFT TORQUE

The torque which is available for doing work is known as shaft torque ( $T_{sh}$ ). It is available for shaft .

The motor output is

$$O/P = T_{sh} * 2\pi n \text{ watt (n in rsp)}$$

$$T_{sh} = \frac{\text{output in watt}}{2\pi n} \text{ N.m (n in rsp)}$$

$$T_{sh} = \frac{\text{output in watt}}{2\pi n/60} \text{ N.m (n in rsp)} \quad \text{N.M.} = \frac{60}{2\pi} * \frac{\text{output}}{N}$$

$$T_{sh} = 9.55 \frac{\text{output}}{N}$$

The difference of ( $T_a - T_{sh}$ ) is known as lost torque and due to iron and frictional losses of the motor.

## CHARACTERISTICS OF THE D.C. MOTOR:

- I.  $T_a \sim I_a$  characteristics
- II.  $N \sim I_a$  characteristics
- III.  $T_a \sim N$  characteristics



# FOR SHUNT MOTOR

It is seen that  $T_a \propto \phi I_a$

$\therefore T_a \propto I_a$  (for shunt motor,  $\phi = \text{constant}$ )

## I. $T_a \sim I_a$ characteristics

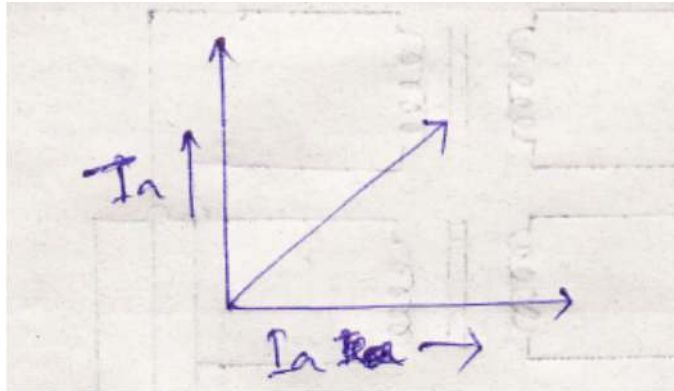

From the above derivation it is seen that proportional to the armature current increases. It is the straight line passes through origin. A heavy starting load will need a heavy starting current. Shunt motor should never be started on heavy load.

## (II) $N \sim I_a$ characteristics

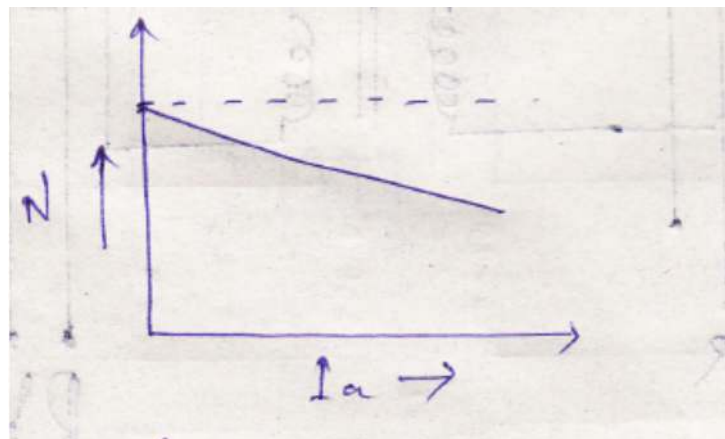

We know that  $N \propto \frac{E_b}{\phi}$

$$N \propto E_b \Rightarrow N \propto V - I_a R_a$$

When armature current increases,  $I_a R_a$  drop increases. The net voltage across the armature decreases. So speed decreases. The decreases in speed is about 10%.

(III)  $T_a \sim N$  characteristics

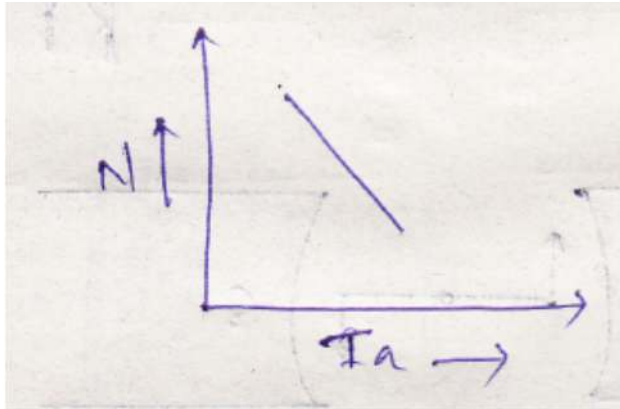

From the above two characteristics . It is seen that, when the torque increases speed decreases.

**FOR SERIES MOTOR** (I)  $T_a \propto \phi I_a$

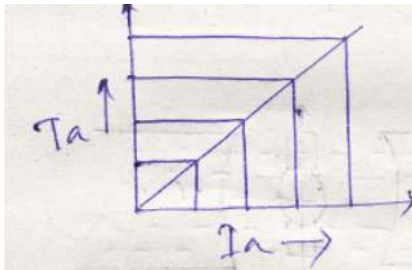

$$T_a \propto \phi I_a^2 (\because \phi \propto I_a)$$

The armature torque ( $T_a$ ) is directly proportional to the square of the armature current.

(II)  $N \sim I_a$  characteristics



$$N \propto \frac{E_b}{\phi}$$

$$N \propto \frac{1}{\phi} \text{ (if } E_b = \text{constant) )}$$

$$N \propto \frac{1}{I_a} \text{ (}\phi \propto I_a\text{)}$$

Speed is inversely proportional to armature current .As the load increases , speed decreases and vice versa . It is a variable speed motor.

It is advised not to start the series motor without load . Since at no load .

The speed of motor will be dangerously high. It should always be started with load.

(III)  $T_a \sim N$  characteristics

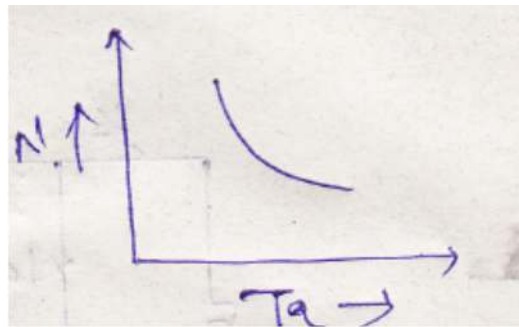

From the above two characteristics . Is seen that, when the speed is high ,torque is low and vice versa.

# FOR COMPOUND MOTOR

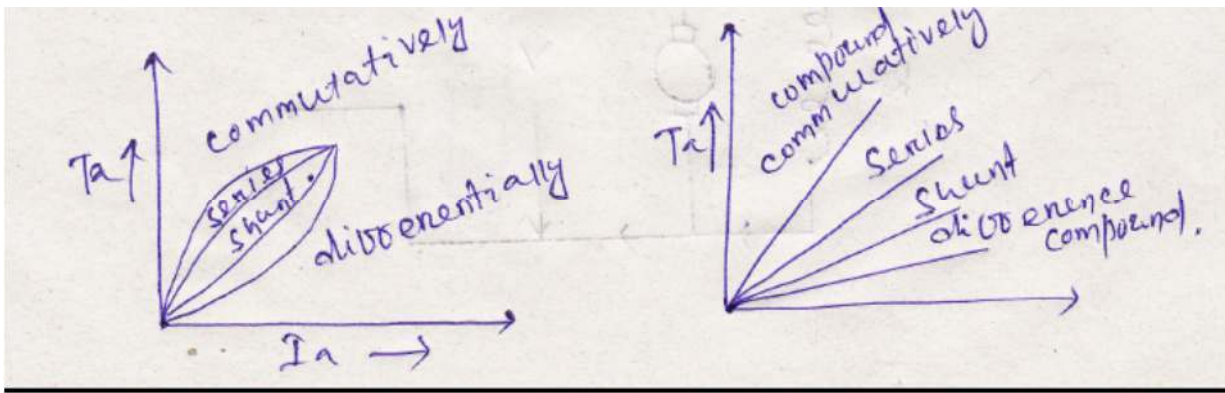

## FOR DIFFERENTIALLY COMPOUND D.C. MOTOR

$$T_a \propto \phi I_a$$

Torque increases as the armature current increases, but this is not so rapidly like commutatively compound D.C. motor, since the series field flux and shunt field flux are opposite to each other. Hence the torque increases.

## FOR COMMUTATIVELY COMPOUND D.C. MOTOR

$$T_a \propto I_a$$

Torque increases rapidly as the armature current increases, since  $T_a \propto \phi I_a$ . As the load current increases, net flux increases.

I.  $N \sim I_a$  characteristics

$$N \propto \frac{E_b}{\phi}$$

$$N \propto \frac{1}{\phi} \text{ (if } E_b = \text{constant)}$$

$$\Rightarrow N \propto \frac{1}{I_a} \text{ (}\phi \propto I_a\text{)}$$

Since " $\phi$ " increases as the series field flux and shunt field aids. So the speed decreases as the armature current increases.

# FOR DIFFERENTIALLY COMPOUND D.C. MOTOR

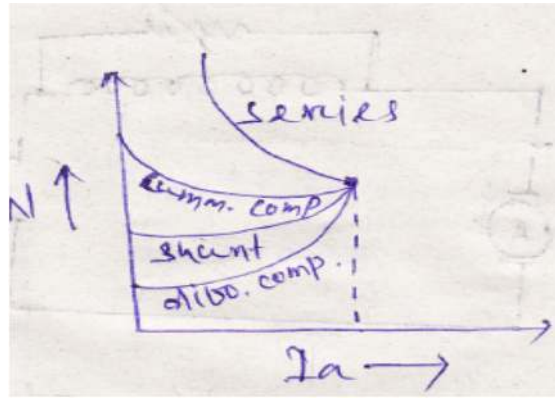

$$N \propto \frac{E_b}{\phi}$$

Since " $\phi$ " increases as series field flux aids, so the speed decreases as the armature current increases.

## USES OF D.C. MOTOR

### (1) SHUNT MOTOR

It is a medium starting torque and nearly constant speed motor. It is used in lathe paper mill, fan etc. Its starting torque is about 1.5 times of full load torque

### (II) SERIES MOTOR:-

It is a high starting torque and variable speed motor. It is used for fraction work. i.e. electrical locomotives, rapid transit system, cars etc. and increases hoists and conveyers.

### (III) COMPOUND MOTOR

DIFFERENTIALLY COMPOUND D.C. MOTOR can be designed to give an accurately constant speed under all conditions. They find limited application for experimental and research work.

Commutatively compound DC motor is high starting torque variable speed motor. It is used in elevator, conveyers, heavy planers, rolling mills, air compression etc.

# SPEED CONTROL OF DC MOTOR

## (1) SHUNT MOTOR

### (a) Armature Voltage Control Method

We know that 
$$\epsilon_b = \frac{P\phi ZN}{60A}$$

$$\Rightarrow N = \frac{60A\epsilon_b}{P\phi Z}$$

$$\Rightarrow N = K \frac{\epsilon_b}{\phi} \text{ (where } K = \frac{60A}{PZ} \text{ i.e. constant)}$$

$$\Rightarrow N \propto \frac{\epsilon_b}{\phi}$$

$$\Rightarrow N \propto \epsilon_b \text{ (for shunt motor)}$$

$$\Rightarrow N \propto V - I_a R_a$$

$$\Rightarrow N \propto V - I_a (R_a + R)$$

An external resistance 'R' is connected in series with the armature circuit in order to vary the drop when the drop increase the voltage across the armature ( $\epsilon_b$ ) decreases. Hence the speed of the motor decreases. In this method speed can be decreased. When the load increases, the speed decreases in speed is about 10%

## (B) FIELD FLUX CONTROL METHOD

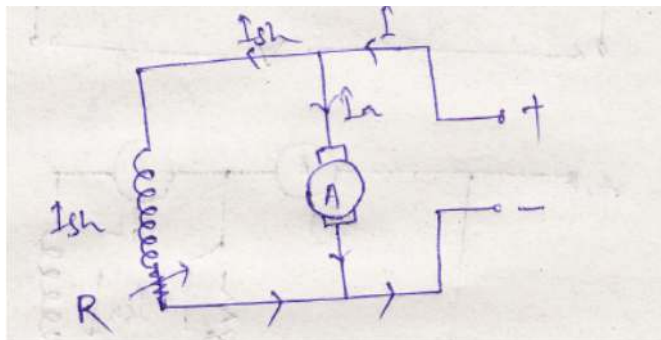

$$\Rightarrow N \propto \frac{E_b}{\phi}$$

$$\Rightarrow N \propto \frac{1}{\phi} \text{ (if } E_b = \text{constant)}$$

$$\Rightarrow N \propto \frac{1}{I_f} \text{ (} \phi \propto I_f \text{)}$$

$$\Rightarrow I_f = I_{sh} = \frac{V}{R_{sh} + R}$$

Hence an external resistance is connected in series with the shunt field. By increasing the shunt resistances, the field current can be decreased since speed is inversely proportional to field current. When the field current decreases, speed increases in ratio 2:1. In this method the speed of the motor is increased.

### (C) WARD-LEONARD METHOD:

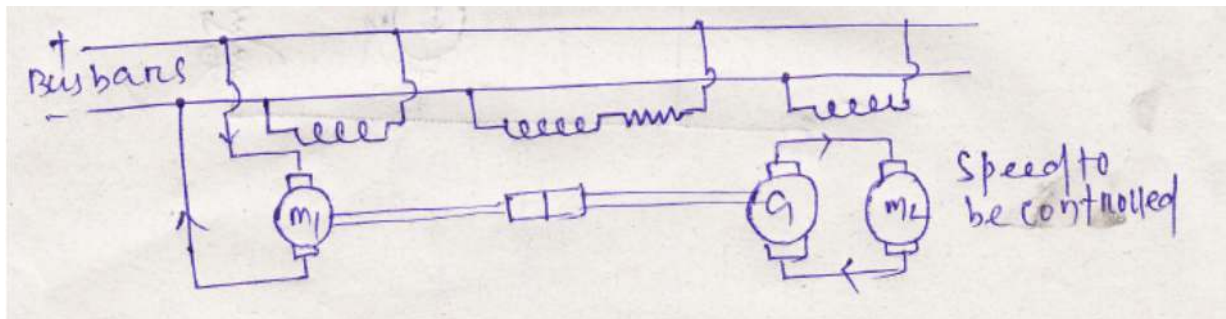

Here motor "M" is mechanically coupled with the generator "G". The output of generator is directly fed to the motor "M<sub>2</sub>" whose speed control is required.

The field of the generator "G" is excited by the bus bar voltage. The field current of generator "G" is can be varied by adjusting the field regulator. The generated EMF (o/p of generator) is input of the motor "M<sub>2</sub>" whose speed is to be controlled. As the speed of the motor "M<sub>1</sub>" varied. The generator EMF of generator is also varied and hence the input of motor "M<sub>2</sub>" varied. In this way the speed of motor is controlled.

This type of speed control is used in elevators, hoists etc.

# SERIES MOTOR

(1) FIELD TAPPING METHOD :- IN this method , deviator point can be moved one point another and there by increasing or decreasing the flux increases number of turns . If the number of turns increases ,then the flux increases , then two field flux increases results decreasing the speed .If the number if turns decreases ,then the field flux decreases result in increasing the speed . This method is often used in electric fraction.

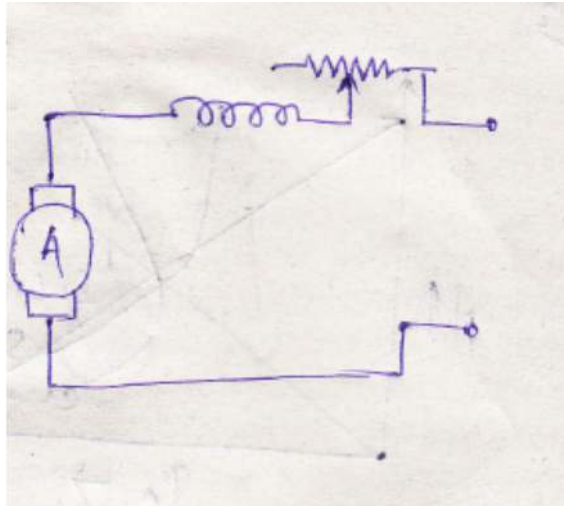

(2) FIELD DIVERTOR METHOD :- A diverter is connected across the series field .any desired amount of current can be passed through the diverter by adjusting the resistance .Hence the flux can be decreased and can continuously , the Speed of the motor increased.

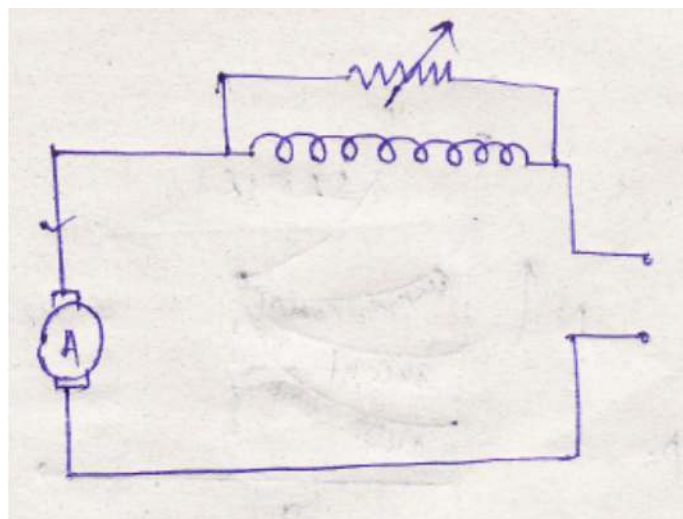



(3) VARIABLE RESISTANCE IN SERIES WITH MOTOR :- By increasing the resistance in series with the armature ,the voltage applied across the armature terminal can be decreased .

With reduce voltage across the armature ,the speed is reduce .How ever it will be noted that since full motor current passes through this resistance there is a considerable loss of power in it .

(4) SERIES PARALLEL METHOD :

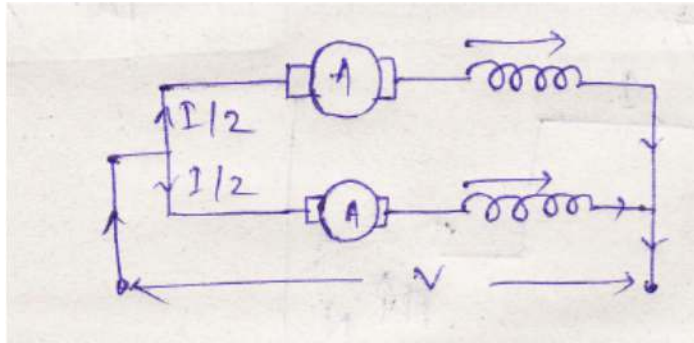

When joined in parallel the voltage across each motor is V through the current drawn by each motor is  $I/2$

$$N \propto \frac{\epsilon_b}{\phi} \propto \frac{\epsilon_b}{I_f} \propto \frac{\epsilon_b}{I/2}$$

Since  $\epsilon_b$  is approximately equal to the apply voltage .

$$N \propto \frac{V}{I/2} \propto \frac{2V}{I}$$

We know that ,  $T_a \propto \phi I_a^2$  (since  $\phi \propto I$ )

$$\text{i.e. , } T_a \propto \left(\frac{I}{2}\right)^2 \propto \frac{I_1^2}{4}$$

WHEN IN SERIES

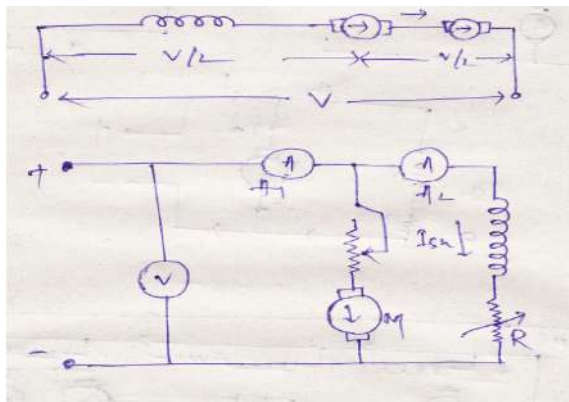

When in series, the two motors have same current the supply voltage becomes half.

$$N \propto \frac{\epsilon_b}{\phi} \propto \frac{V/2}{I}$$

$$N \propto \frac{V}{2I}$$

This speed is one fourth of the speed as compared to when connected in parallel.

## WHEN IN PARALLEL

Similarly  $T_a \propto \phi I \propto I^2$

The torque is four times of that produced by the motor when in parallel.

At high speeds, the motors join in parallel. At the time of starting, the D.C. series motor are connected in series to obtain high starting torque. But at the time of running, they are connected in parallel to obtain very high speed.

## SWIN BURNE'S TEST

It is suitable for shunt motors. It is a simple method in which the losses are measured separately and the efficiency at any desired load can be determined in which flux is practically constant.

The machine runs as a motor on no-load at its rated voltage. The speed is adjusted in the rated speed with the help of shunt Regulator.

The no-load current " $I_0$ " is measured by the ammeter "A" and shunt field current " $I_{sh}$ " is measured by ammeter "A<sub>2</sub>"

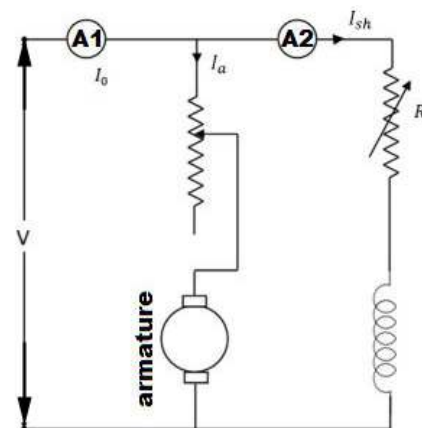

Initially there is no-load in motor,

Let  $V$  = supply voltage

$I_0$  = no-load current

$$I_{sh} = \text{shunt field current} = V/R_{sh}$$

$$I_{a0} = I_0 - I_{sh} = \text{no-load armature current .}$$

$$\text{No -load input to motor} = VI_0 \text{ watt}$$

At no-load ,I/P=losses

$$VI_0 = W_c + I_{a0}^2 R_a$$

$$\text{Constant loss } W_c = VI_0 - I_{a0}^2 R_a$$

WHEN LOAD

I= load current at which efficiency is required

V= supply voltage

∴ motor input =VI watt

Armature current  $I_a = I - I_{sh}$  (if m/c motoring)

$I_a = I + I_{sh}$  (if m/c in generating )

FOR MOTOR

$$\eta = \frac{\text{output}}{\text{input}} = \frac{\text{input} - \text{losses}}{\text{input}}$$

$$\eta = \frac{VI - (W_c + I_a^2 R_a)}{VI} \quad ( I_a = I - I_{sh} \text{ for motor} )$$

FOR GENERATOR

$$\eta = \frac{\text{output}}{\text{input}} = \frac{\text{OUTPUT}}{\text{OUTPUT} + \text{LOSSES}}$$

$$\eta = \frac{VI}{I + (W_c + I_a^2 R_a)} \quad ( I_a = I + I_{sh} \text{ for generator} )$$

# DETERMINATION EFFICIENCE BY BREAK TEST

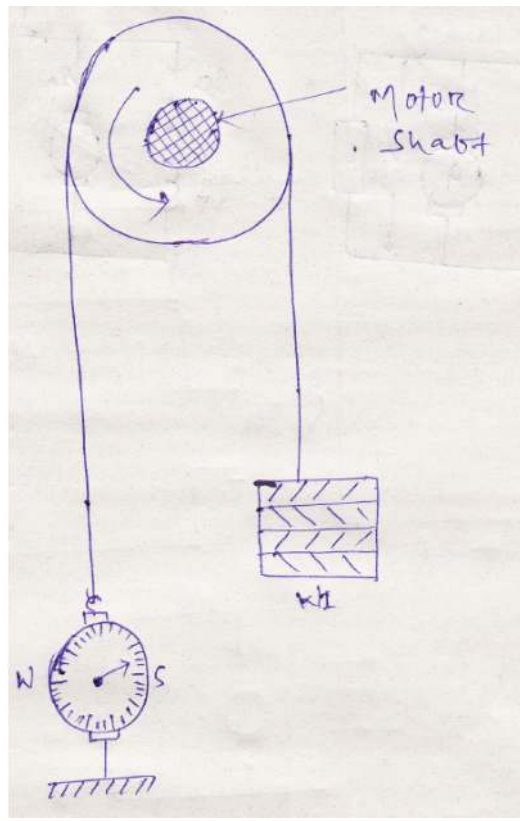

One end of the band is fixed to earth via spring balance and the other is connected to a suspended weight  $W_1$ .

The motor runs and the load on the motor is adjusted till it carries its full load current.

Let  $W_1$  =suspended weight in  $K_g$ .

$W_2$  = Reading on spring balance in  $K_g$ .

The net pull on the band due to friction at the pulley is  $(W_1 - W_2) K_g$ .

$$F=9.81(W_1 - W_2)\text{Newwton}$$

If  $R$ =Radius of pulley in meter .

$N$ =Motor or pulley speed in rsp.

Then, shaft torque developed b the motor.

$$T_{sh} = 9.81(W_1 - W_2) R \quad \text{N-m.}$$

$$\text{Motor output power} = T_{sh} * 2\pi N \text{ shaft}$$

$$= 61.68N (W_1 - W_2) R \text{ watt.}$$

Let V=supply voltage.

I=Full load current taken by motor.

Then motor input power =VI Watt.

The efficiency of the motor is given by

$$\text{Efficiency} = \frac{\text{Output power}}{\text{Input power}}$$

$$\text{Efficiency, } \eta = \frac{61.68N(W_1 - W_2) R}{VI}$$

## NECESSITY OF STARTERS

At the time of starting, the back emf is zero. The armature resistance is also very small. Hence the current that flows through the armature is very large.

$$I_a = \frac{V - \varepsilon_b}{R_a} = \frac{V - 0}{R_a} = \frac{V}{R_a}$$

At the time of starting, the D.C. motors draw very very high current which is about 15 to 20 times of their full load current, the motor may burn. In order to save the motor from no-load and over load and also low limit the starting current starter are necessary.

Starter is a device, which will limit the starting current and also provides no-load and over load protection.

There are three types of starters.

### (1) 3 Point starter.

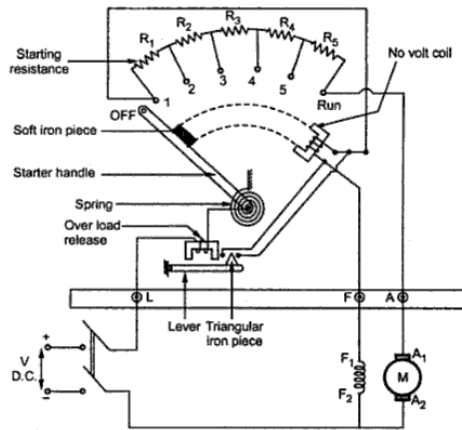

**3 point Starter**

It is used for starting of dc shunt motor.

### (2) 4-point starter.

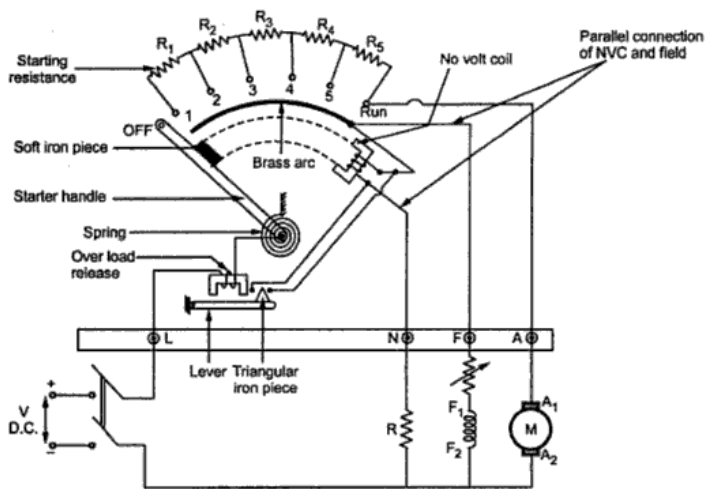

**4 point Starter**

It is used for compound motor.

(3) Drum controller.

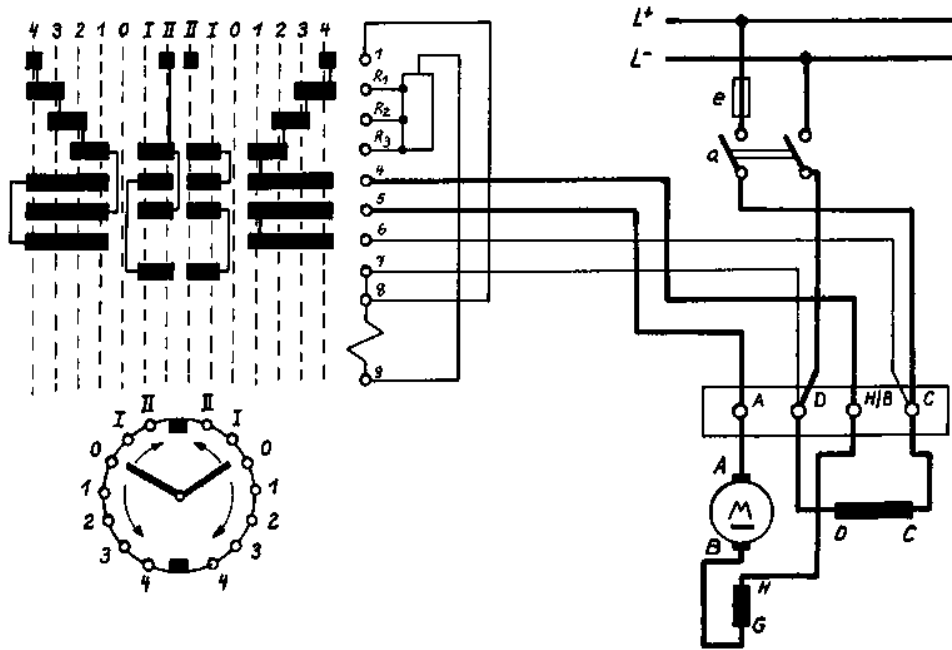

It is used for to starting speed control of several rotation of dc series motor.

# TRANSFORMER





# SINGLE PHASE TRANSFORMER

Definition:-

It is a static electrical device which transfers ELECTRICAL power(energy) from one winding to another winding without changing its frequency.

WORKING PRINCIPLE:

It works on FARADAY'S law of ELECTROMAGNETIC induction (i.e-whenver the flux linked with a coil changes an emf induced in it). Basically it works on Mutual induction.

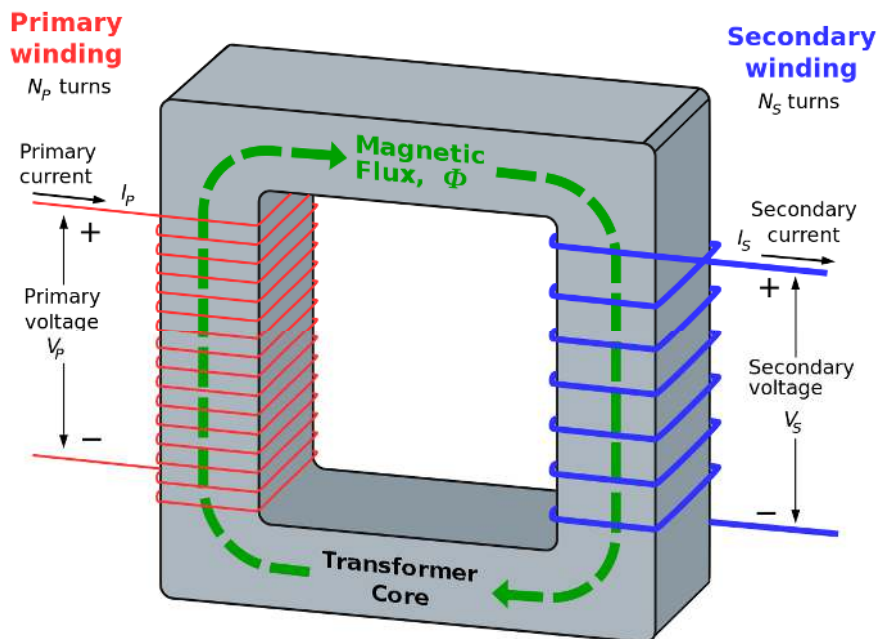

It consist of two winding and laminated core is made of SILICON STEEL material .the order of lamination is 0.35mm to 0.5 mm one winding is wound over one limb and another winding is wound over another limb . The winding which is connected to supply is known as PRIMARY winding and the winding from which the load is taken is known as SECONDARY winding. When the primary winding is connected to A.C. supply. An alternating current flows through it,which

produces an alternating flux .This alternating flux circulates through the core and also links to the secondary winding .

The emf induced in the primary winding is due to flux by the principle of self induction .

$$E_1 = -N_1 \frac{d\phi}{dt} \text{ ----- (1)}$$

The emf is induced in the secondary winding due to mutual inductance  $E_2$  .

$$E_2 = -N_2 \frac{d\phi}{dt} \text{ ----- (2)}$$

Where  $N_1$  and  $N_2$  are the number of turn in primary and secondary respectively.

$$\frac{E_2}{E_1} = \frac{N_2}{N_1} = K$$

Where “K” is the turn ratio or Transformer ratio.

## EMF EQUATION OF TRANSFORMER

Let  $N_1$  = Number of turn in primary winding .

$N_2$  = Number of turn in secondary winding .

$\Phi_m$  = Maximum Flux density (in web )

$B_m$  =Maximum flux density (in *Web/m<sup>2</sup>*)

A =Area of cross-section of core( in *m<sup>2</sup>*)

F= frequency (in *H<sub>z</sub>*)

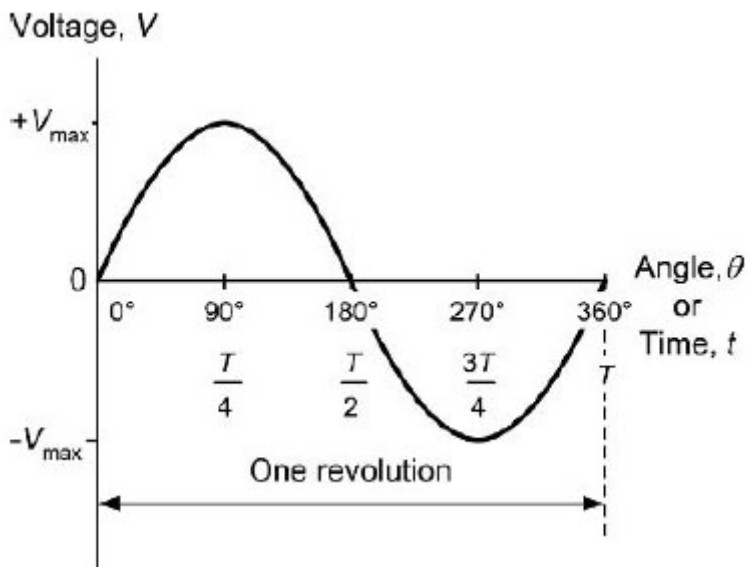

Fig

The average value of induced EMF in primary winding .

$$E_1 = -N_1 \frac{d\phi}{dt}$$

$$E_1 = N_1 \left( \frac{\phi_m - 0}{T/4 - 0} \right)$$

$$= N_1 \left( \frac{\phi_m}{T/4} \right)$$

$$= \frac{4N_1 \phi_m}{T}$$

$$= 4N_1 \phi_m \left( f = \frac{1}{T} \right)$$

RMS value of induced EMF in primary winding

$$E_1 = 1.11 * 4fN_1 B_m A$$

Similarly EMF induced in secondary side

$$E_2 = 4.44fN_2 B_m A$$

# CLASSIFICATION OF TRANSFORMER

According to USE

- (i) STEP UP TRANSFORMER :- If the secondary voltage is more than the primary voltage then it known as step up transformer.

$$V_2 > V_1, N_2 > N_1, K > 1$$

- (ii) STEP DOWN TRANSFORMER

If the secondary voltage is less then the primary voltage then it is known as step-down transformer.  $V_2 < V_1, N_2 < N_1, K < 1$

- (iii) IDEAL TRANSFORMER

If the secondary voltage is equal to the primary voltage ,then it is known as ideal transformer.  $V_2 = V_1, N_2 = N_1, K = 1$

Input = Output

$$\Rightarrow V_1 I_1 = V_2 I_2$$

$$\Rightarrow \frac{V_2}{V_1} = \frac{I_1}{I_2} = K$$

There is no losses .Efficiency is 100%

$$\frac{V_2}{V_1} = \frac{E_2}{E_1} = \frac{N_2}{N_1} = \frac{I_1}{I_2} = K$$

# ACCORDING TO CONSTRUCTION

## I. Core type transformer

In this type of transformer, the windings surrounding a considerable part of the core.

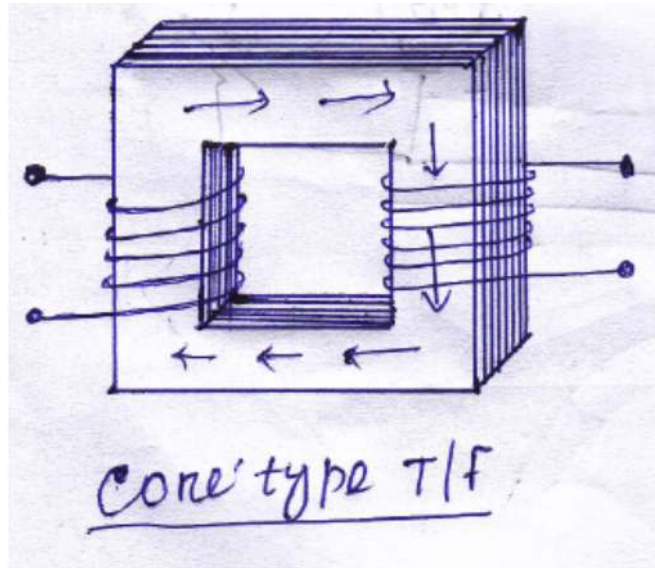

## II. Shell type transformer

In this type of transformers, the core surrounds a considerable portion of the windings.

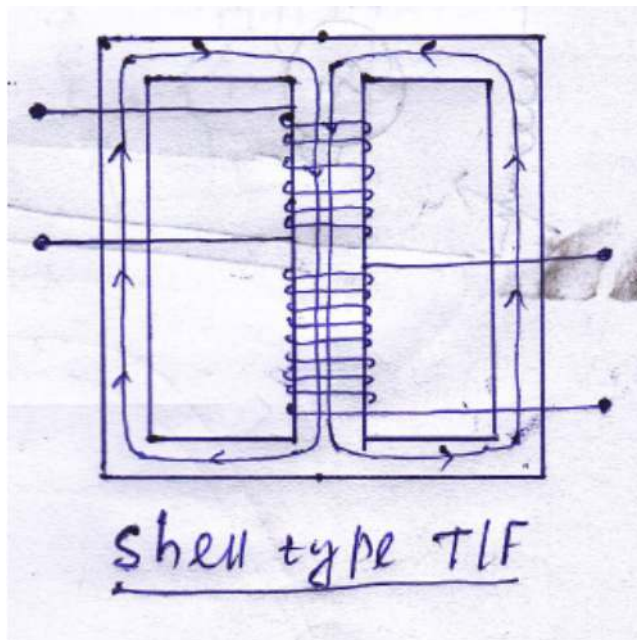

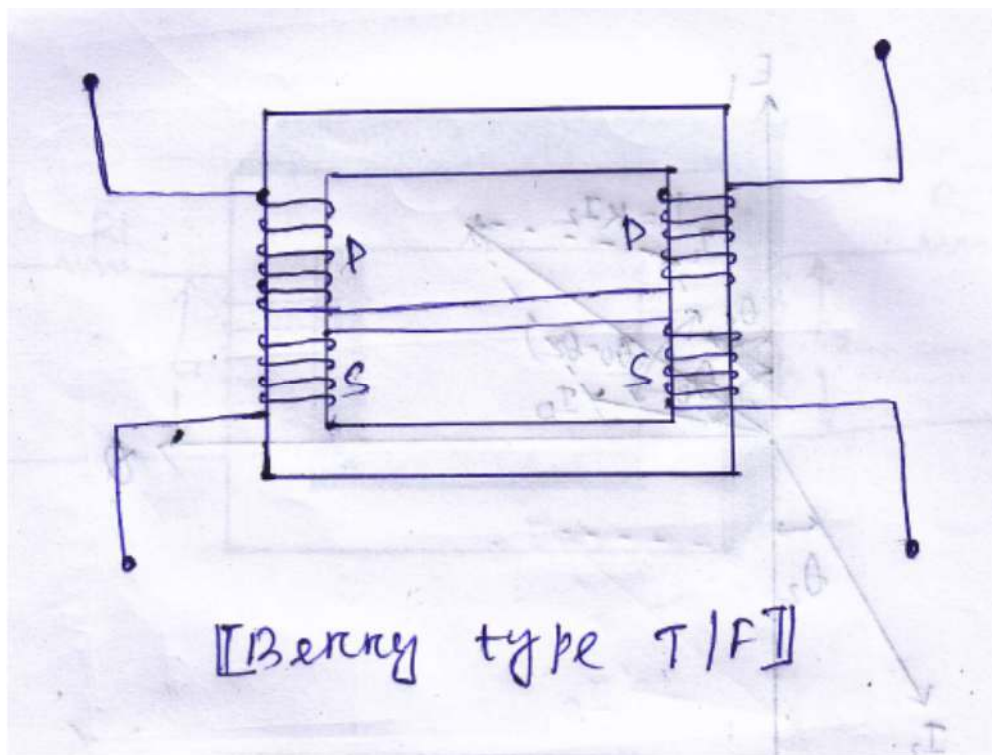

In this type of transformers, half the primary and half the secondary winding have been placed side by side or concentrically on each limb. This type of transformer are also known as spiral core type transformers.

## TRANSFORMER ON NO- LOAD

If the primary winding is connected to supply and secondary winding is open circuited then it is known as no- load condition of transformer.

The current drawn in this condition is ' $I_0$ ' is known as no-load current of the transformer. It is known about 1% to 3% of the full load current. The no load current lags the supply voltage  $V_1$  by an angle  $\phi_0$ . It has two components.

- (i)  $I_0 \cos \phi_0 = I_w$  is known as working component of no load current.
- (ii)  $I_0 \sin \phi_0 = I_\mu$  is known as magnetising component of no load current.

$I_w$  is in phase with supply voltage  $V_1$ . The magnetizing component  $I_\mu$  is in quadrature with supply voltage  $V_1$

$$I_w^2 + I_\mu^2 = I_0^2$$

The watt meter reading indicates the losses of the transformer

This loss is known as  $P_0 = V_1 I_0 \cos \phi_0$  the iron loss or constant loss. Since the current drawn by the transformer under no-load condition is very very small that is why the copper loss is neglected.

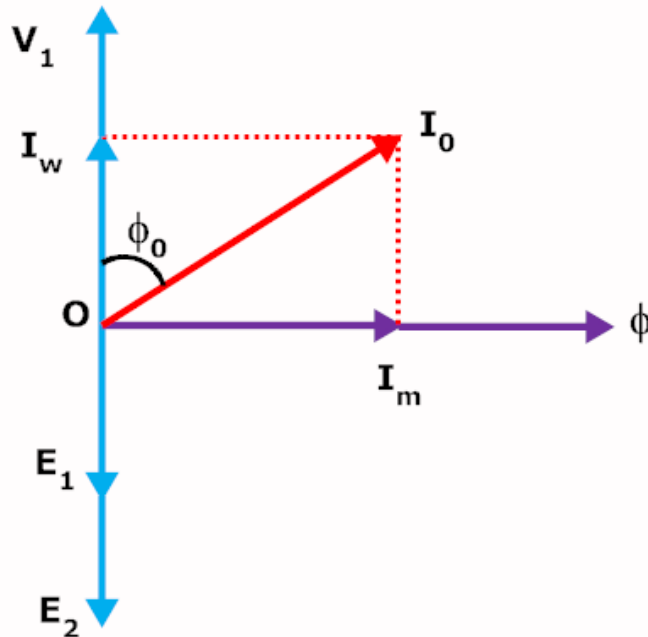
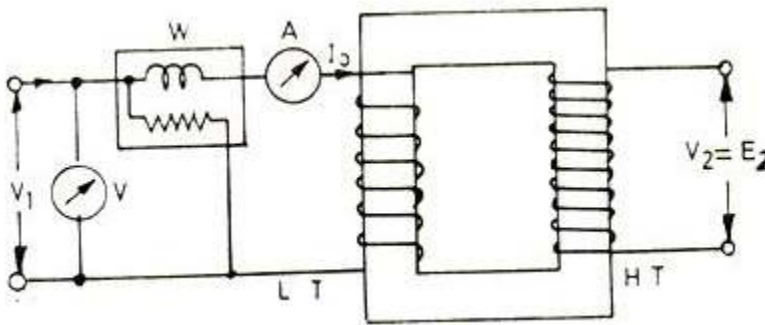
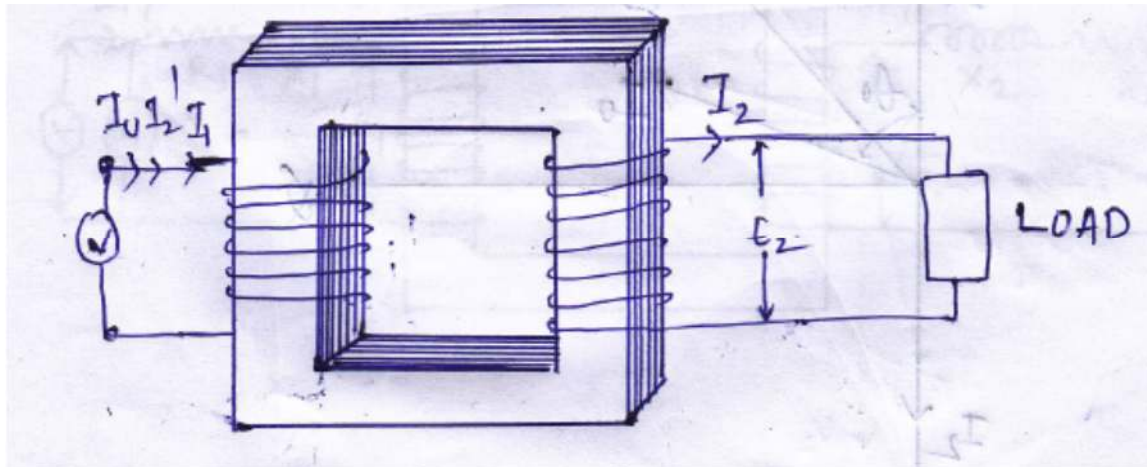

Figure 4: Phasor diagram of practical transformer on no load



# TRANSFORMER ON LOAD

The primary is connected to supply and the load is taken .The no-load current drawn by the transformer is  $I_0$ .



When the load is increases , The current should be increased in the secondary sides. But at every instant in order to meet the load current ,the secondary EMF  $E_2$ .Flux  $\phi$  should be increased . According to Lenz's law every change in opposed at every instant . Hence it not possible to change the flux, when the load increases or decreases accordingly .

When the load current increases to " $I_2$ " in the secondary ,the current in the primary side will be " $I_2$ " which is the additional current drawn by the transformer from the source .

Flux produced in the primary is equal to the flux produced in this secondary .

$$\phi_2' = \phi_2$$

$$N_1 I_2' = N_2 I_2$$

$$I_2' = \frac{N_2 I_2}{N_1}$$

# INDUCTIVE LOAD

$$I_1 = I_0 + I_2' \text{ (Vector sum)}$$

$$\sqrt{I_0^2 + (I_2')^2 + 2I_0I_2' \cos(\phi_0 - \phi_2)}$$

Here  $I_2'$  lags angle  $\phi_2$  to the voltage  $V_2$  or  $E_2$ .

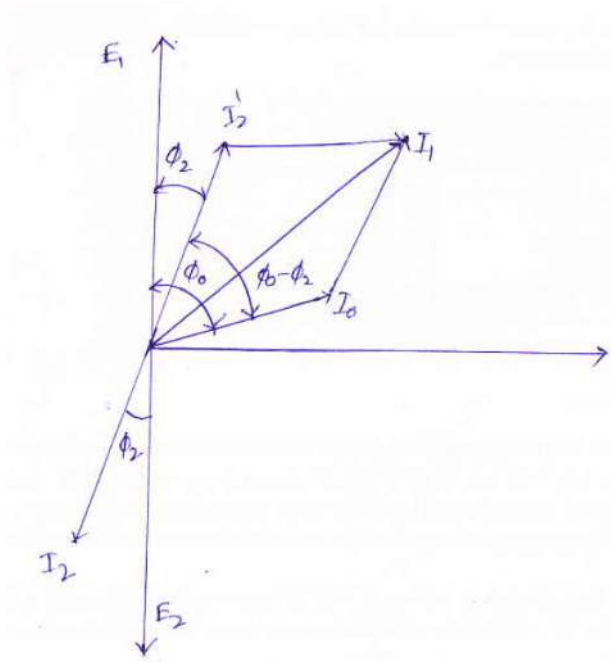



# TRANSFORMER WITH WINDING RESISTANCE

An ideal transformer should not pass resistance, but in actual transformer, there is always present some resistance of primary and secondary winding. Due to this resistance, there is some voltage drop in the two windings.

The secondary voltage  $V_2$  is vectorially less than the secondary induced emf  $E_2$  by an amount  $I_2 R_2$ ; where  $R_2$  is the resistance at the secondary winding.

$$V_2 = E_2 - I_2 R_2 \text{ (only taking resistance)}$$

[vector difference]

- i. The primary induced EMF " $E_1$ " is equal to the vector difference of  $V_1$  and  $I_1 R_1$ .  
Where  $R_1$  is the resistance of the primary winding.

$$V_1 = E_1 + I_1 R_1 \text{ (Only taking resistance, vector difference)}$$

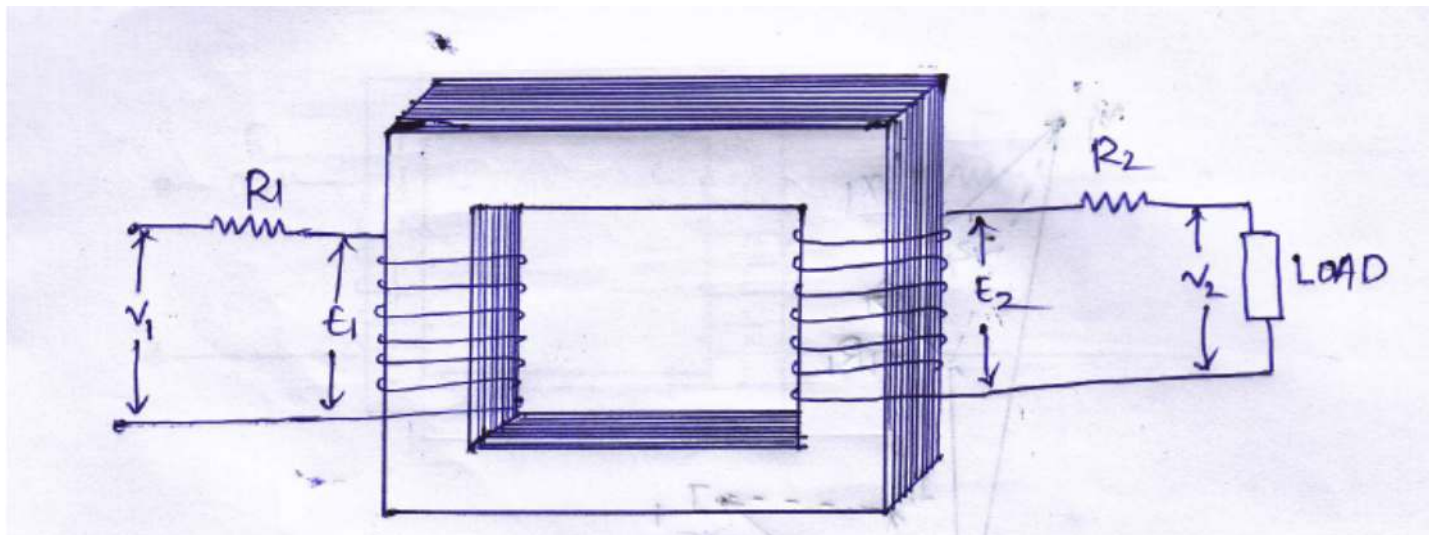

# MAGNETIC LEAKAGE

In winding, the secondary winding. But actual practice it is not possible. It is found that, all flux linked with primary does not link secondary winding. But a part of it that is  $\Phi_{L1}$ , complete through the primary winding. This flux  $\Phi_{L1}$  is known as primary leakage flux. Similarly  $\Phi_{L2}$  is linked with secondary with is known as secondary leakage flux. It induces a self induced EMF  $\Phi_{L2}$  in secondary winding due to leakage flux  $\Phi_{L2}$ .

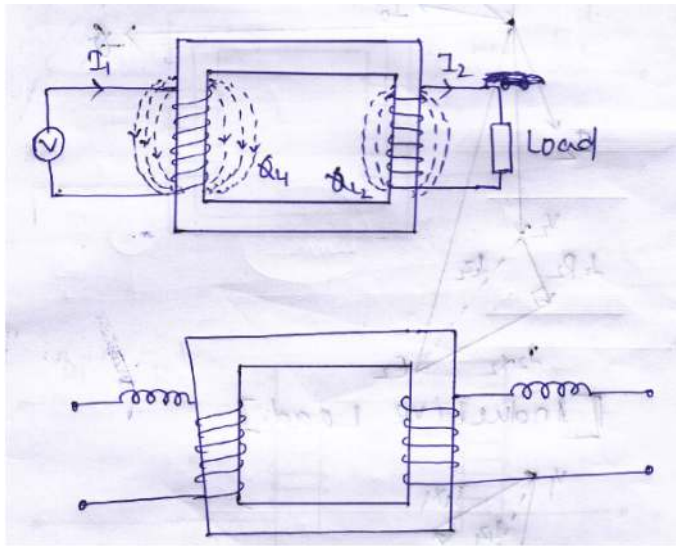

$$X_2 = \frac{\Phi_{L2}}{I_2}$$

Where  $X_1$  and  $X_2$  are known as the primary and secondary leakage reactance respectively combining both resistance and reactance

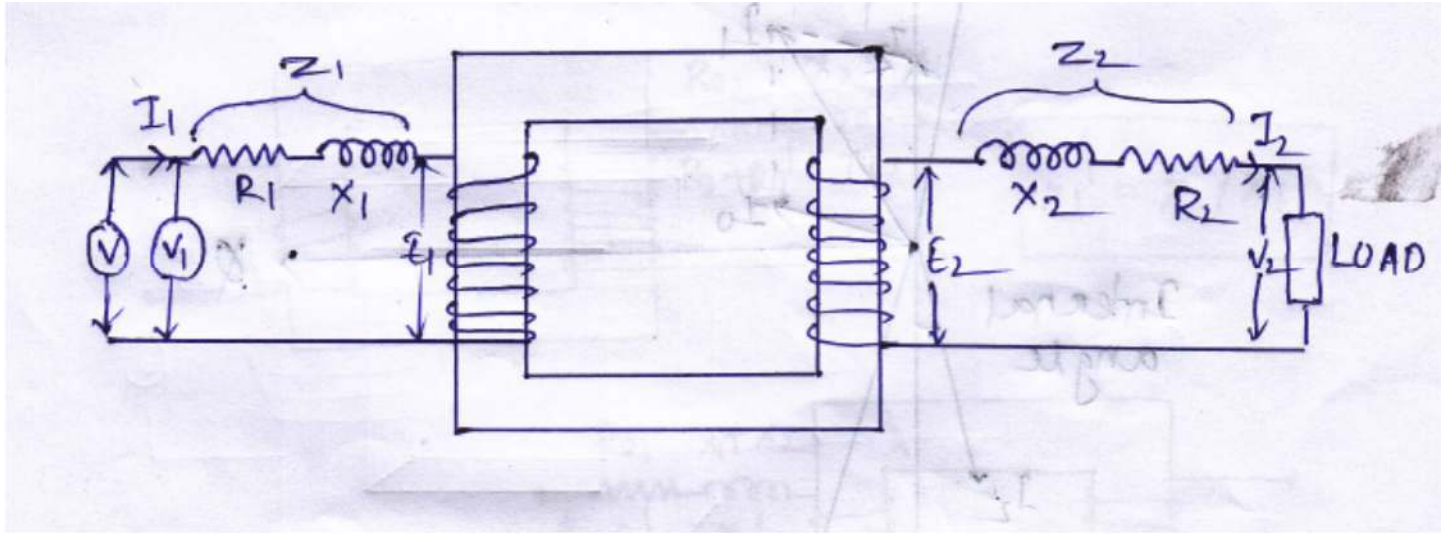

The primary impedance is given by

$$Z_1 = R_1 + jX_1$$

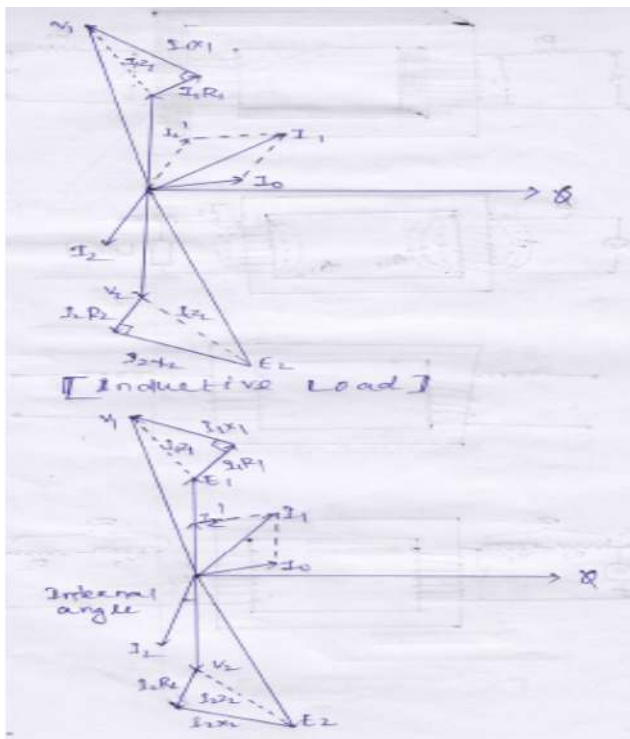

Equivalent Resistance, Reactance and Impedance



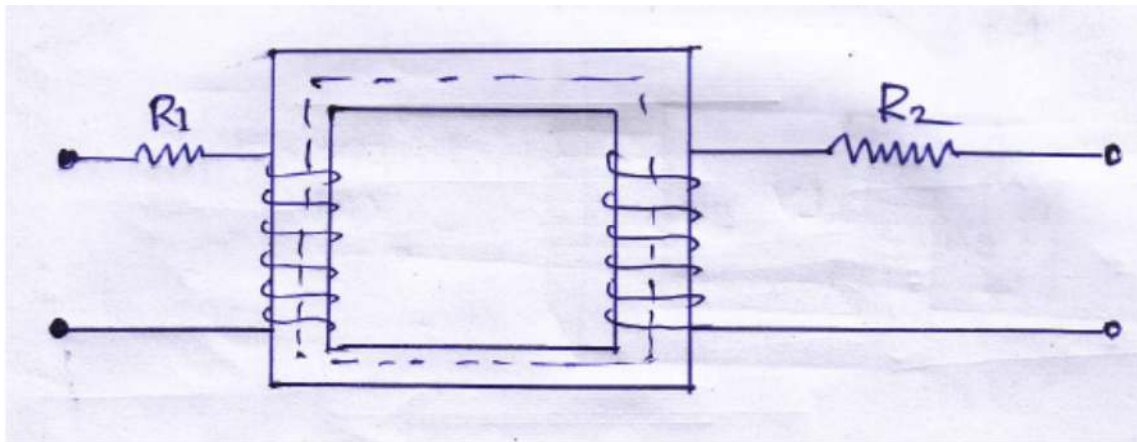

Let the resistance of primary winding =  $R_1$

The resistance of secondary winding =  $R_2$

Let  $R_1'$  be the primary resistance as referred to secondary

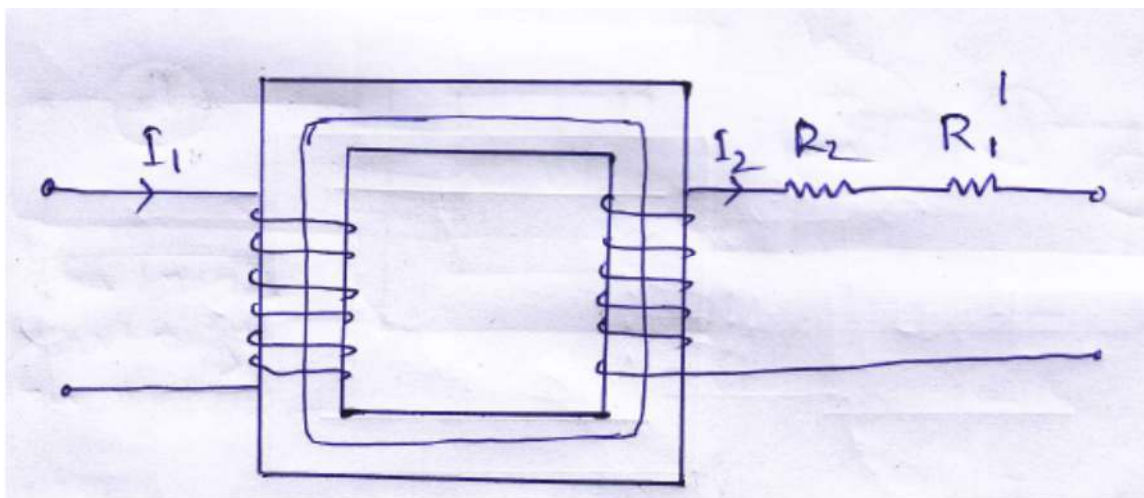

$$I_1^2 R_1 = I_2^2 R_1'$$

Equivalent resistance of the transformer as referred to secondary is given by

$$R_{02} = R_2 + R_1' = R_2 + K^2 R_1$$

Similarly,  $R_2'$  be the secondary resistance as referred to primary



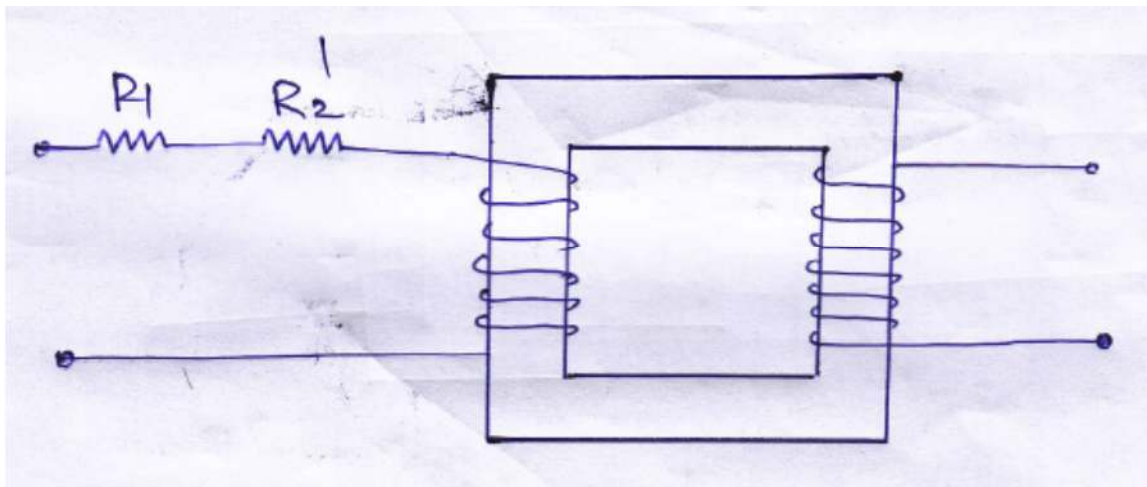

$$I_2^2 R_2 = I_1^2 R_2^1$$

$$\text{i.e. } R_2^1 = R_2 / K_2^2$$

Equivalent resistance of the transformer as referred to the primary is given by

The resistance can also be transformed from one winding to the other in the same way as resistance.

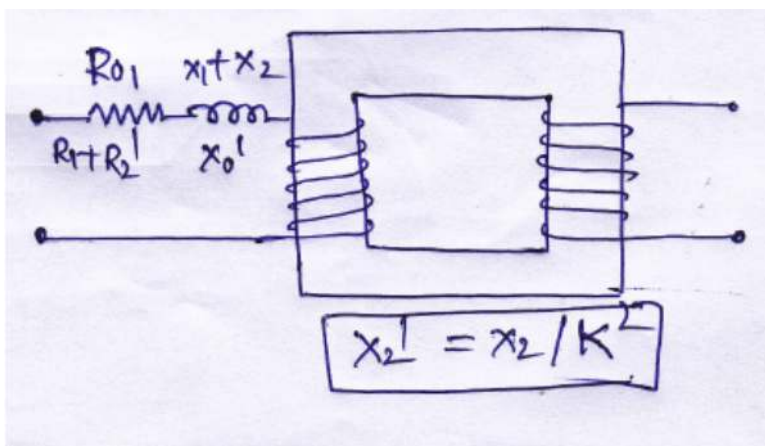
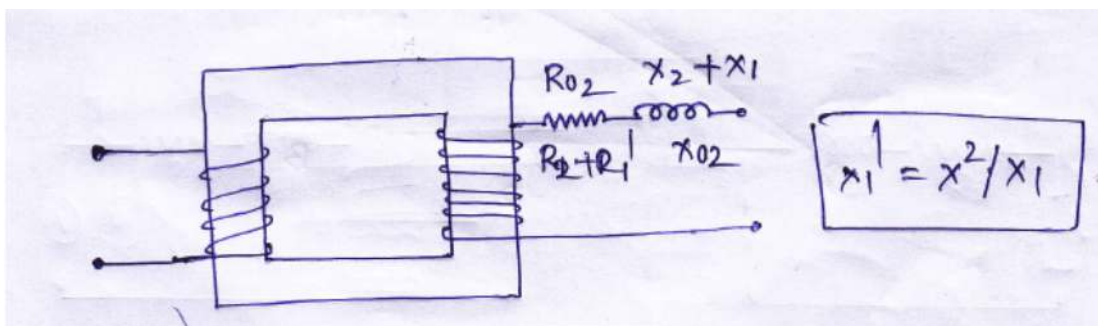

$$X_1^1 = K^1 X_1$$

$$X_2^1 = X_2 / K^2$$

Total equipment reactance as referred to secondary is given by

$$X_{02} = X_2 + X_1^1 = X_2 + K^2 X_1$$

Total equipment reactance as referred to primary is given by

$$X_{01} = X_1 + X_2^1 = X_1 + X_2 / K^2$$

Now Total equipment impedance as referred to secondary is given by

$$Z_{02} = R_{02} + jX_{02}^1 = \sqrt{(R_{02}^2 + X_{02}^2)}$$

Total equipment impedance as referred to primary is given by

# TESTS ON TRANSFORMER

## (1) Open –circuit or no load test

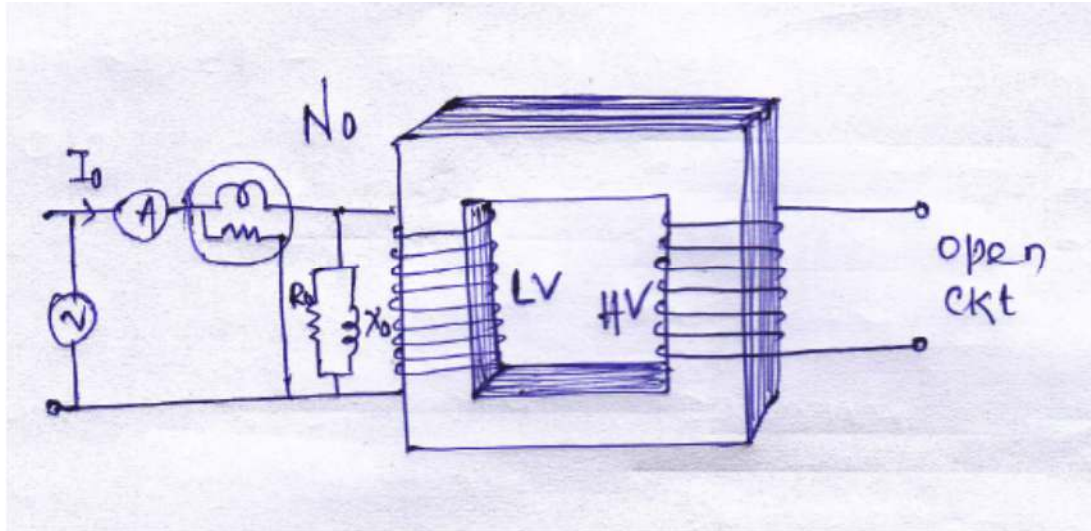

In case of no load test, the low voltage winding is connected to supply of ratted voltage and frequency .The high voltage side's is open circuited . Another voltmeter 'V<sub>2</sub>' is connected across high voltage side . The voltage should be adjusted until the voltage across 'V<sub>2</sub>' is the voltage mentioned in the name plate . The watt meter shows the iron loss . Since the no-load current is very very small ,copper loss is neglected . Then iron loss=

$$\omega_0 = V_1 I_0 \cos\phi_0$$

$$I_0 \cos\phi_0 = \frac{\omega_0}{V_1} \Rightarrow I_w = \frac{\omega_0}{V_1} \dots\dots\dots \text{Working component of no load}$$

$$I_\mu = \sqrt{I_0^2 - I_w^2}$$

Magnetizing components of no-load current

$$R_0 = \frac{V_1}{I_w}$$

$$X_0 = \frac{V_1}{I_\mu}$$

Where  $R_0$  = Resistance of the exciting coil

$X_0$  = Reactance of the exciting coil

## (2) Short Circuit Test

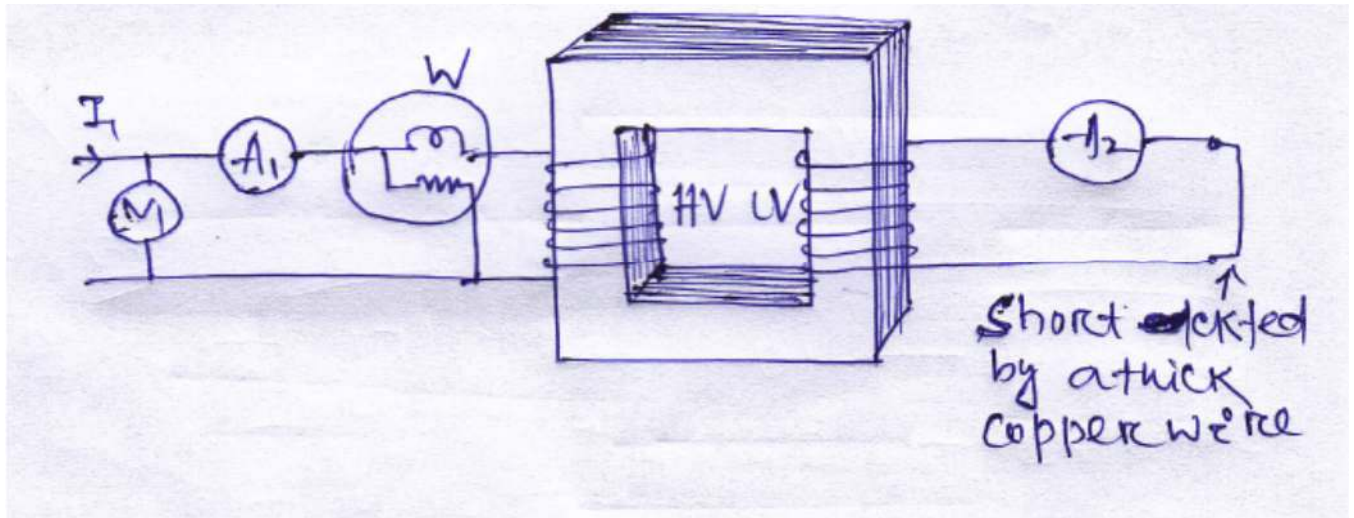

The H.V. side of the transformer is connected to the supply and all the instruments are connected in the primary side. The L.V. side is short circuited by a thick copper wire. A small voltage will be applied to the H.V side and the voltage is adjusted until the ammeter  $A_2$  shown the full load current in secondary.

If  $V_c$  is the voltage required to calculate the related load current then

$$Z_{01} = \frac{V_{sc}}{I_1}$$

The wattmeter shown full load copper loss

$$W = I_1^2 R_{01} \quad \uparrow$$

full load copper loss  $\downarrow$

<del>Wattmeter</del> $R_{01} = \frac{W}{I_1^2}$
$X_{01} = \sqrt{Z_{01}^2 - R_{01}^2}$
$R_{02} = K^2 R_{01}$
$Z_{02} = K^2 Z_{01}$

$$X_{02} = K^2 X_{01}$$

$R_{01} = \frac{R_{02}}{K^2}$
$Z_{01} = \frac{Z_{02}}{K^2}$
$X_{01} = \frac{X_{02}}{K^2}$

Taking  $V_2$  as reference :

Taking  $I_2$  as reference :

$$E_2 = OX = \sqrt{OB^2 + BX^2}$$

$$= \sqrt{(OA + AB)^2 + (BD + DX)^2}$$

=

$$\sqrt{(V_2 \cos \phi_2 + I_2 R_{02})^2 + (V_2 \sin \phi_2 + I_2 X_{02})^2}$$

$$E_2$$

$$= \sqrt{(V_2 \cos \phi_2 + I_2 R_{02})^2 + (V_2 \sin \phi_2 + I_2 X_{02})^2}$$

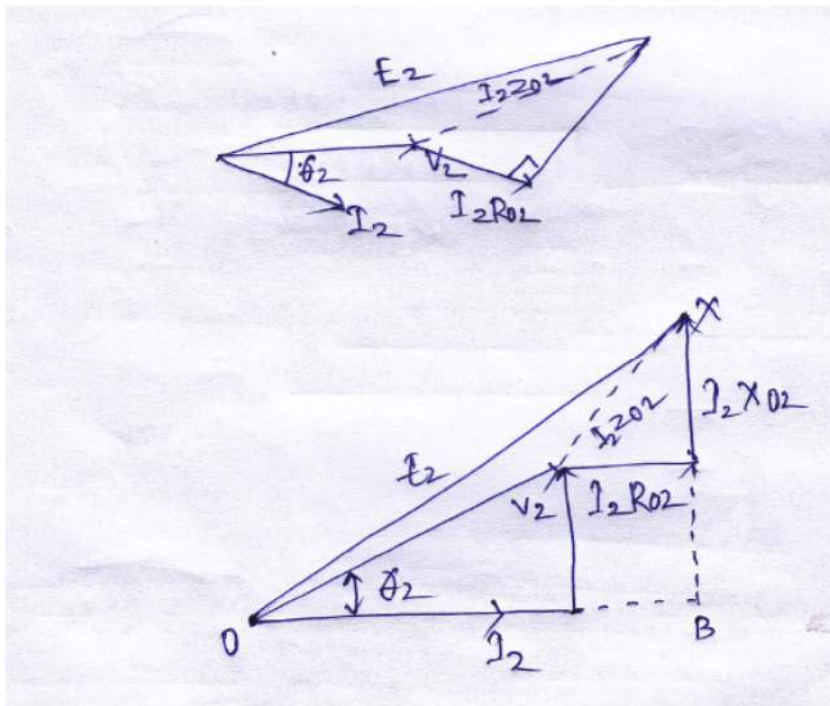

# VOLTAGE REGULATION

It is defined as the change in secondary terminal voltage from no-load to full-load divided by full-load terminal voltage .

$$\%VR = \frac{E_2 - V_2}{V_2} * 100$$

$$\%VR = \frac{\text{no load voltage} - \text{full load voltage}}{\text{full load voltage}} * 100$$

$$= \frac{\text{drop}}{\text{full load voltage}} * 100$$

$$\text{i.e. } \%VR = \frac{I_2 (R_2 \cos \phi_2 \pm X_{02} \sin \phi_2)}{V_2} * 100$$

“+” sign for lagging power factor

“-” Sign is for leading power factor

$\%VR \text{ (up)} = \frac{E_2 - V_2}{V_2} * 100$
$\%VR \text{ (down)} = \frac{E_2 - V_2}{E_2} * 100$

# EQUIVALENT CIRCUIT OF A TRANSFORMER

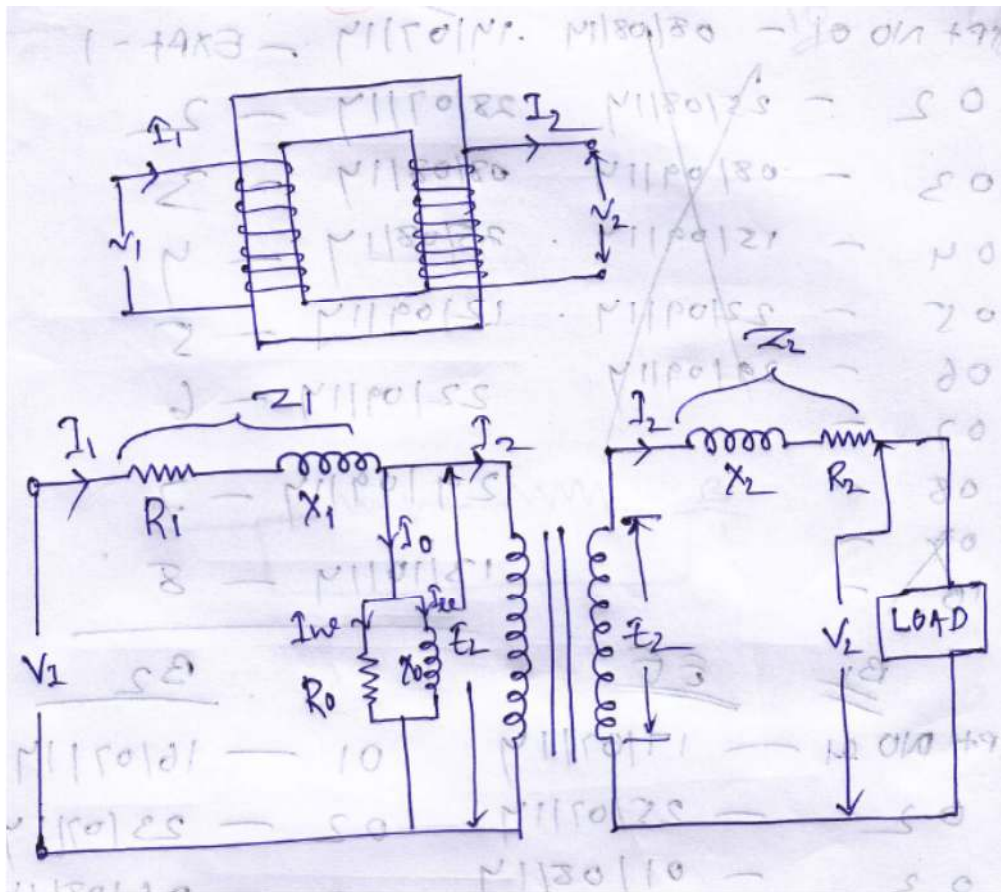

$R_0$  is the resistance of the exciting coil

$$R_0 = \frac{V_1}{I_w}$$

$X_0$  is the resistance of the exciting coil

$$X_0 = \frac{V_1}{I_\mu}$$

$Z_m$  is connected in parallel with  $X_0$

$$Z_m \parallel R_0$$

$Z_m$  = Impedance of the coil

$$Z_m = X_0 \parallel R_0 = \frac{X_0 R_0}{X_0 + R_0}$$



$$Z_{1\phi} = R_{1\phi} + jX_{1\phi}$$

$$Z_{2\phi} = R_{2\phi} + jX_{2\phi}$$

$E_{1\phi}$  and  $E_{2\phi}$  are related to each other by the expression TypeEquationHere.

$$\frac{E_{2\phi} N_{2\phi}}{E_{1\phi} N_{1\phi}} = K$$

Now transforming the secondary side parameters to primary side.

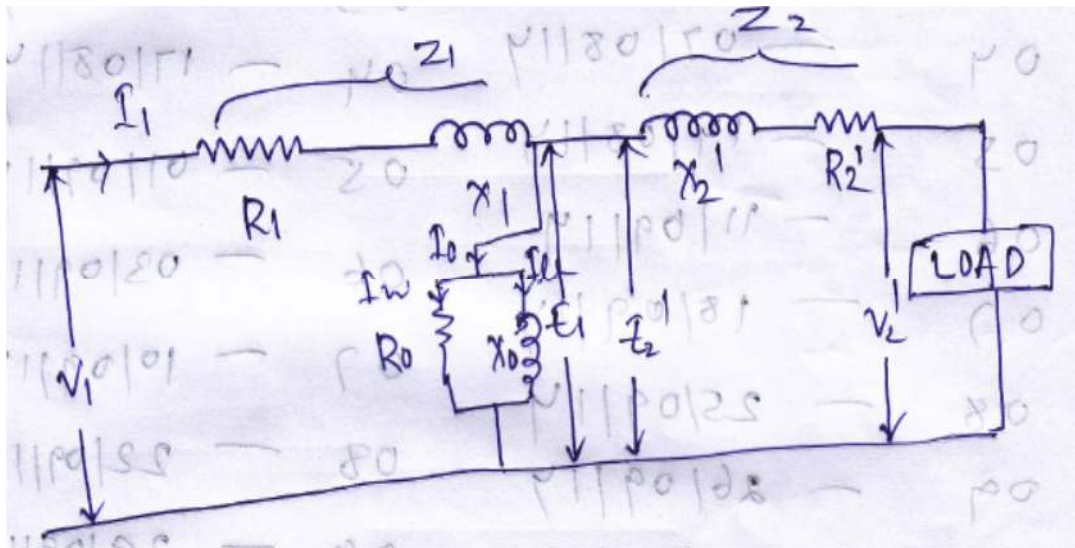

The primary equivalent of secondary induced EMF

$$E_{2\phi}' = E_{2\phi} / K = E_{1\phi}$$

Similarly The primary equivalent of secondary terminal voltage

$$V_{2\phi}' = V_{2\phi} / K$$

The primary equivalent of secondary terminal current

$$I_{2\phi}' = K I_{2\phi}$$

Transforming the secondary impedance to primary



$$R_{2\prime} = R_2/K^2, X_{2\prime} = X_2/K^2, R_{L\prime} = R_L/K^2, X_{L\prime} = X_L/K^2,$$

Now, equivalent impedance of transformer in primary side,

$$Z = R_{1\prime} + jX_{m\prime} \parallel (R_{2\prime} + jX_{L\prime})$$

$$\text{Primary current} = I_1 = \frac{V_1}{Z} = \frac{V_1}{R_{1\prime} + jX_{m\prime} \parallel (R_{2\prime} + jX_{L\prime})}$$

Further simplifying the act For easy calculation .

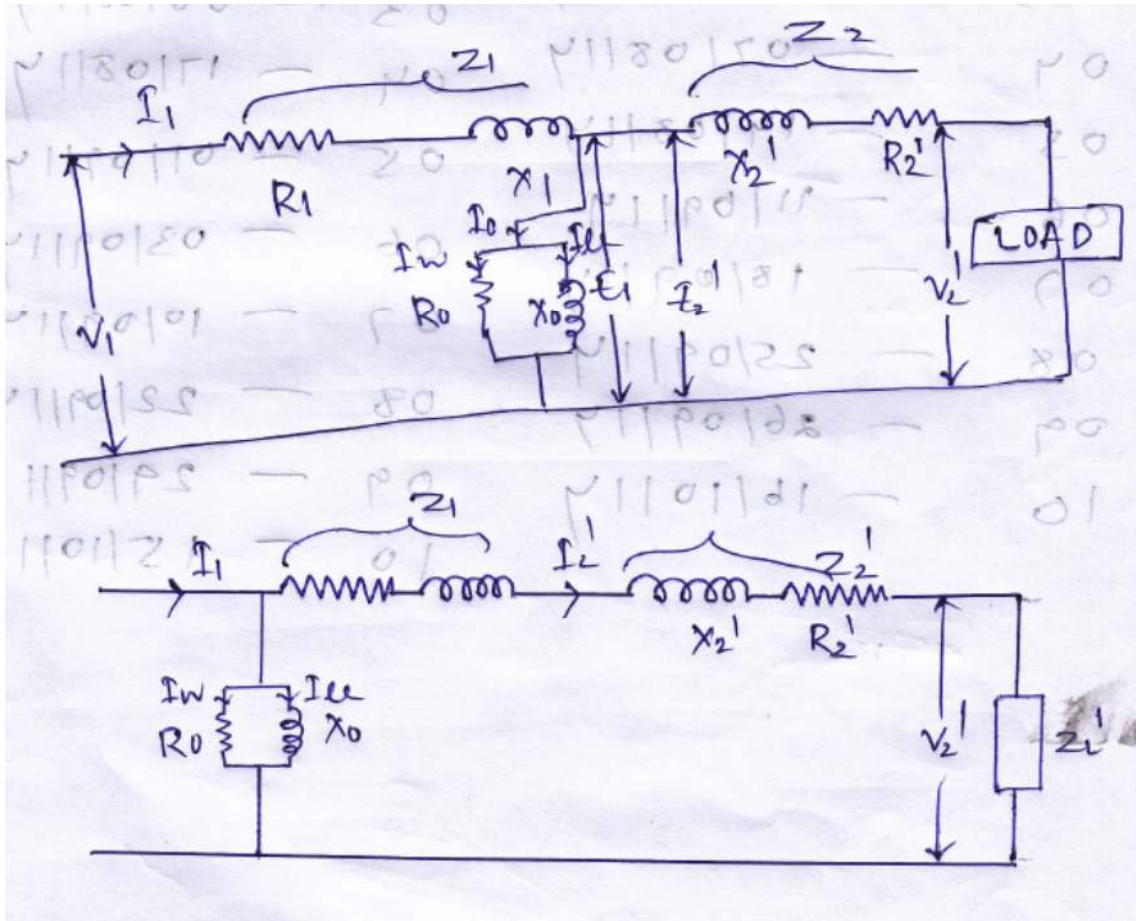

# LOSSES IN A TRANSFORMER

Since transformer is a static electrical device, hence there no mechanical loss. There occurs only copper and iron loss.

## IRON LOSS

(a) Hysteresis loss

(b) Eddy current loss

(a) Hysteresis loss

Hysteresis loss occurs due to the reversal of magnetism

(b) Eddy current loss

When the transformer is connected to alternating source an alternating flux is produced in the winding of the transformer. This flux links to the core of the transformer and EMF is induced in the cores of the transformer. Since the transformer core is having low resistance and closed one. So a current flows in the core of the transformer. That is known as EDDY current. The loss which occurs due to this eddy current is known as EDDY current loss.

## 2: COPPER LOSS

$$\text{COPPER LOSS} = I_1^2 R_1 + I_2^2 R_2$$

$$= I_1^2 R_{01}$$

$$= I_2^2 R_{02}$$

## EFFICIENCY OF THE TRANSFORMER

It is defined as the ratio of output to input

$$\text{Efficiency} = \frac{\text{OUTPUT}}{\text{INPUT}}$$

$$\eta = \frac{\text{OUTPUT}}{\text{INPUT}}$$

$$= \frac{\text{OUTPUT}}{\text{OUTPUT} + \text{LOSSES}}$$

$$= \frac{\text{OUTPUT}}{\text{output} + \text{iron loss} + \text{copper loss}}$$

$$\eta = \frac{V_2 I_2}{V_2 I_2 + W_i + I_2^2 R_{02}}$$

## CONDITION FOR MAXIMUM EFFICIENCY

The efficiency will be maximum when  $\frac{d\eta}{dI_2} = 0$

$$\Rightarrow \frac{d}{dI_2} \left( \frac{V_2 I_2}{V_2 I_2 + W_i + I_2^2 R_{02}} \right) = 0$$

$$\Rightarrow \frac{(V_2 I_2 + W_i + I_2^2 R_{02}) V_2 - V_2 I_2 (V_2 + 2I_2 R_{02})}{(V_2 I_2 + W_i + I_2^2 R_{02})^2} = 0$$

$$\Rightarrow (V_2 I_2 + W_i + I_2^2 R_{02}) V_2 = V_2 I_2 (V_2 + 2I_2 R_{02})$$

$$\Rightarrow (V_2 I_2 + W_i + I_2^2 R_{02}) = V_2 I_2 + 2I_2^2 R_{02}$$

$$\Rightarrow W_i + I_2^2 R_{02} = 2I_2^2 R_{02}$$

$$\boxed{W_i = I_2^2 R_{02}}$$

Efficiency of the transformer will be maximum

When, iron loss = copper loss or Constant loss = Variable loss

The output current corresponding to maximum efficiency  $I_2 = \sqrt{\frac{W_i}{R_{02}}}$

Load KVA corresponding to maximum efficiency

$$\boxed{\text{Load KVA (max)} = \text{full load KVA} * \sqrt{\frac{\text{IRON LOSS}}{\text{FULL LOAD LOSS}}}}$$

# ALL DAY EFFICIENCY

The primary of the transformer is always connected to the source. The load is taken from the secondary . The iron loss depends on voltage and frequency. But the copper loss depends on current . when the load increases , output current of the transformer also increases and vice-versa since the primary is always connected to the source for 24hours. So iron loss occurs for 24 hours . But the copper loss varies according to the load . Hence the all day efficiency is given by .

$$\text{Efficiency all day} = \frac{\text{output in Kwh}}{\text{input in Kwh}} \text{ ( For 24 hours )}$$

## WHY TRANSFORMER IS RATED IN KVA?

Copper loss of a transformer depends on current and iron loss on voltage . Hence total transformer loss depends on volt ampere (VA) and not on phase angle between voltage and current , it is independent of load power factor . That is why rating of transformer is in KVA not in KW.

## PARALLEL OPERATION OF 1-PHASE TRANSFORMER

For supplying a load in excess of the rating of the exciting transformer, a second transformer may be connected in parallel with it. The primary windings are connected to the supply bus-bars and the secondary windings are connected to load bus-bars.

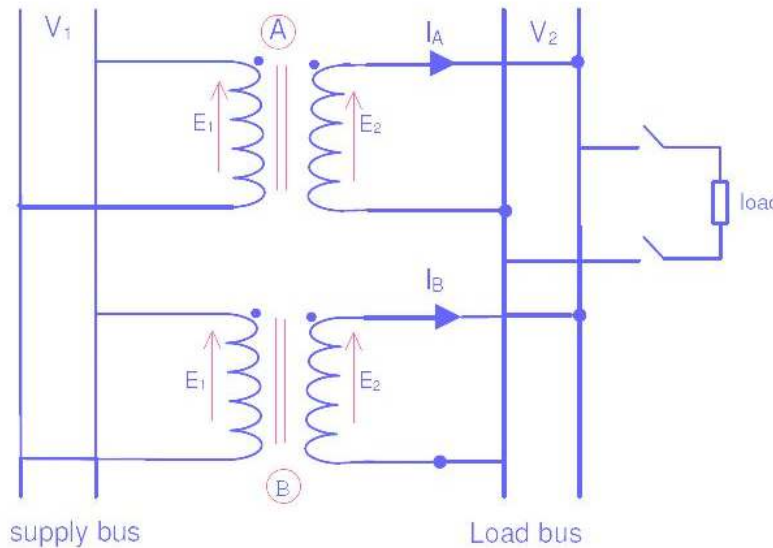
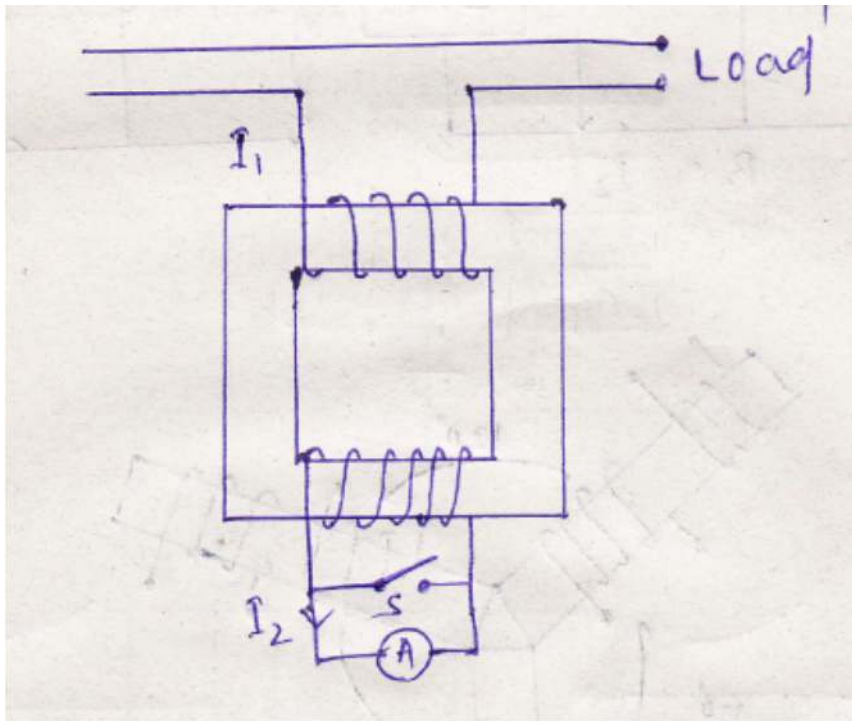

Figure 37: Parallel Operation of Two Single Phase Transformers - Physical

### CONDITION

- (1) Polarity must be maintained.
- (2) Voltage and frequency must be same.
- (3) Turn ratio must be same.
- (4) KVA rating should be same.
- (5) If the KVA rating of the two transformers are different then the percentage of impedance ratio of the transformer inversely proportional to their KVA rating
- (6) Percentage of impedance should be equal in magnitude and have the same ratio if the rating of the two transformer and will be equal.
- (7) The construction of two transformer should be same.

## CURRENT TRANSFORMER[CT].



It is a step up transformer .It is used for the measurement of high current in high voltage alternating current circuit where it is not possible to connected the instrument directly .The CT has a primary coil of few turns but of thick wire connected in series with the load ,whose current is to be measured. The secondary consists of a large number of turns of fine (thin) wire ,and is connected with an ammeter .The ammeter reads the current in the secondary of C.T. .The actual current of the load is given by

$$I_1 = KI_2 \text{ [Where } K = \frac{N_2}{N_1} \text{]}$$

It should be noted that since the ammeter resistance is very low ,the C.T should never be kept open under any because the EMF induced in the secondary side of C.T is very very high .If for any reason ,the ammeter is taken out of the secondary winding ,then this winding must be short circuited with the help of a short circuiting switch's.

# POTENTIAL TRANSFORMER [P.T]

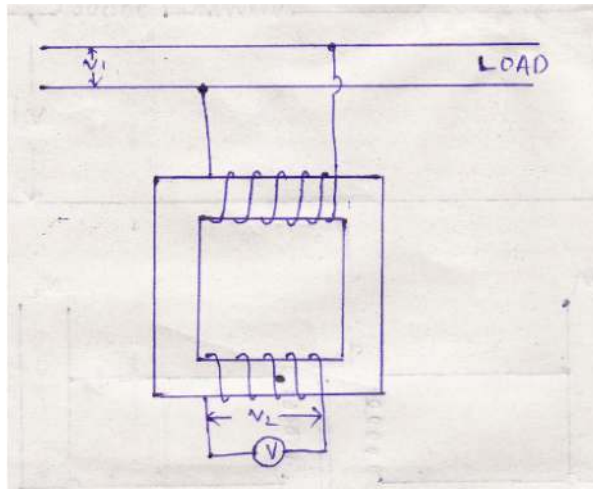

It is a step-down transformer .The primary side will be connected in parallel with the bus-bar ,whose voltage is to be measured .The secondary side of the P.T is connected with a voltmeter, which will measure the voltage across the secondary. This voltage where divided be the voltage transformation ratio (K)given the true voltage in the high voltage side.

$$V_1 = V_2 / K$$

For safety ,the secondary should be completely insulated in addition grounded for affording protection to the operation .This secondary of P.T should not short circuited since the current in the secondary is very very high .Both C.T and P.T are used in protection purpose.

# AUTO-TRANSFORMER

It is a transformer with one winding only serving common to both primary and secondary winding .Both primary and secondary are not electrical isolated from each other ,as in ease of a two winding transformer .Due to one winding ,the copper is use in compression to a two winding transformer .Hence it is cheaper than a two winding transformer .The losses of an auto transformer is less than a two winding transformer is more than a two winding transformer.

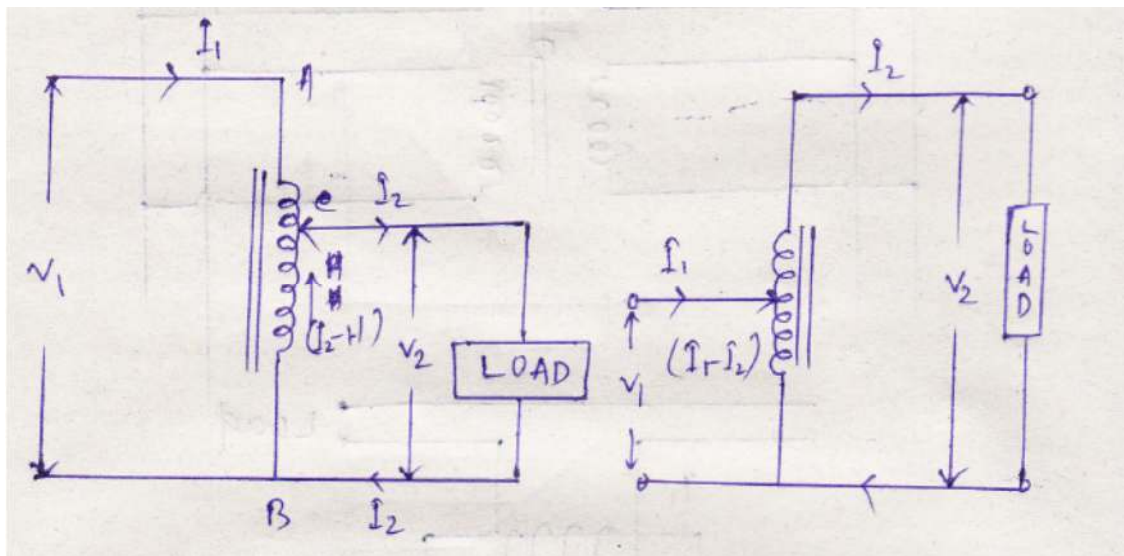

The current in section CB is vector difference of  $I_2$  and  $I_1$ . But as the two currents are practically in phase opposition, the resultant current is  $(I_2 - I_1)$  where  $I_2 > I_1$

In fact ,current flowing in the common winding of the auto .It is always equal to the different between primary and secondary currents of an ordinary transformer.

$$AB=N_1; BC=N_2$$

$$AC= (N_1 - N_2)$$



$$K = \frac{N_2 I_1}{N_1 I_2}$$

## SAVING OF COPPER

$\omega t$  of Cu  $\propto$  current \* No of turns

i.e.  $\omega \propto (N_1 I)$

$\omega t$  of section AC is  $\propto (N_1 - N_2) I_1$

$\omega t$  of section BC is  $\propto N_2 (I_2 - I_1)$

Total  $\omega t$  of in auto transformer  $\propto (N_1 - N_2) I_1 + N_2 (I_2 - I_1)$

If two winding transformer were to perform

The same duty, then  $\omega t$  of copper on its primary  $\propto N_1 I_1$

$\omega t$  of copper on its secondary  $\propto N_2 I_2$

Total  $\omega t$  of cu in 2-winding transformer  $\propto N_1 I_1 + N_2 I_2$

$$\frac{\omega t \text{ of Cu in auto transformer}}{\omega t \text{ of Cu in 2-winding transformer}} = \frac{(N_1 - N_2) I_1 + N_2 (I_2 - I_1)}{N_1 I_1 + N_2 I_2}$$

$$\text{i.e. } \frac{\omega_a}{\omega_0} = \frac{N_1 I_1 - N_2 I_1 + N_2 I_2 - N_2 I_1}{N_1 I_1 + N_2 I_2}$$

$$= \frac{N_1 I_1 - N_2 I_1 + 2 N_2 I_1}{N_1 I_1 + N_2 I_2}$$

$$= \frac{N_1 I_1 + N_2 I_2}{N_1 I_1 + N_2 I_2} = \frac{2 N_2 I_1}{N_1 I_1 + N_2 I_2}$$

$$= 1 - 2 \frac{N_2 I_1 / N_1 I_1}{N_1 I_1 / N_1 I_1 + N_2 I_2 / N_1 I_1}$$

$$= 1 - 2 \frac{N_2 / N_1}{1 + N_2 / N_1 \cdot I_2 / I_1} \quad (\text{Taking } \therefore N_2 / N_1 = K)$$

$$= 1 - 2 \frac{K}{1 + K \cdot \frac{1}{K}} = 1 - 2 \frac{K}{1 + 1} = 1 - \frac{2K}{2}$$

i.e.  $\frac{\omega_a}{\omega_0} = 1 - K$

$$\omega_a = 1 - K(\omega_0)$$

( $\omega_t$  of cu in auto transformer) =  $1 - K(\omega_t$  of the ordinary transformer)

Saving of cu =  $\omega_0 - \omega_a$

$$= \omega_0 - 1 - K(\omega_0)$$

$$= \omega_0 - \omega_0 + K\omega_0$$

Sa cu. saving =  $K * \omega_t$ . Of cu in ordinary transformer

Saving will be increased as it approaches to unity

- ✓ Power transferred inductivity =  $(1 - K)I/P$
- ✓ Power transferred conductivity =  $K \cdot I/P$

# THREE-PHASE TRANSFORMER CONNECTIONS

A three-phase transformer can be built by suitable connecting a bank of three single-phase transformer. The primary or secondary may be connected in either star( $\gamma$ ) or delta( $\Delta$ ) arrangement. The four most common connections are

- (i)  $\gamma$ - $\Delta$
- (ii)  $\Delta$ - $\Delta$
- (iii)  $\gamma$ - $\Delta$
- (iv)  $\Delta$ - $\gamma$

These four connections are shown in fig. In this fig, the windings at the left are the primaries and those at the right are the secondaries.

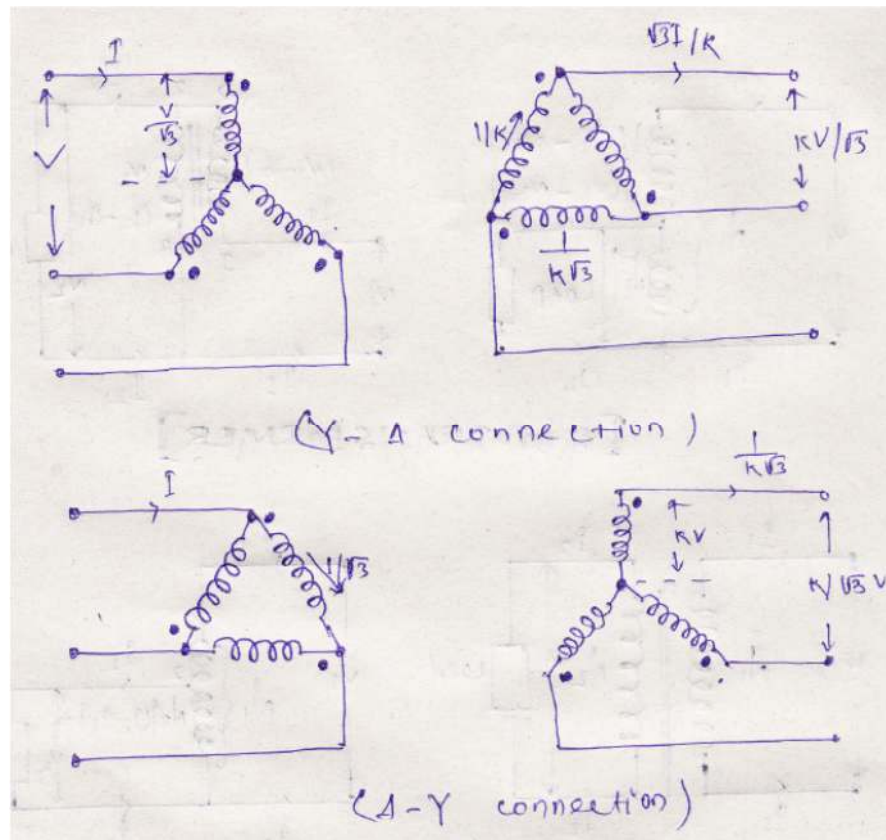

# THREE PHASE TRANSFORMER CONNECTION

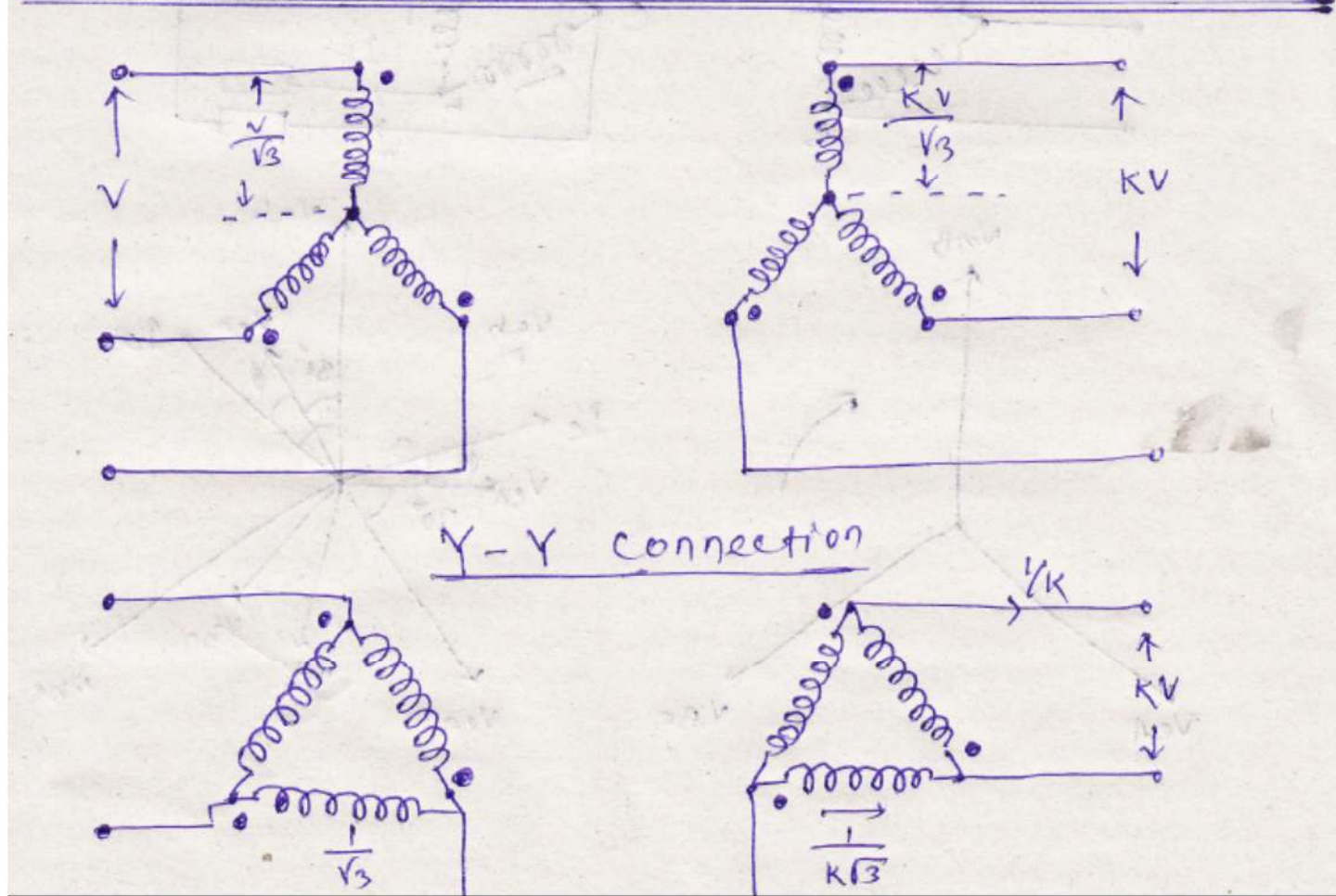

The primary and secondary voltage and currents are also shown. The primary line voltage is  $V$  and the primary line current is  $I$ . The phase transformer ratio  $K$  is

given by ; 
$$K = \frac{\text{Secondary phase voltage}}{\text{primary phase voltage}} = \frac{N_2}{N_1}$$

(i)  $\gamma$ - $\gamma$  connection :- In the  $\gamma$ - $\gamma$  connection shown in fig (i) 57.7% (or  $1/\sqrt{3}$ )

Of the line voltage is impressed upon each winding but full line current flows in each winding. Power circuits supplied from a  $\gamma$ - $\gamma$  bank often creates serious disturbances in communication circuits in their immediate vicinity. Because of this and other disadvantage, the  $\gamma$ - $\gamma$  connection is seldom used.

(ii)  $\Delta$ - $\Delta$  connection – The  $\Delta$ - $\Delta$  connection shown in fig ..... (ii) is often used for moderate voltages .An advantage of this connection is that if one transformer gets damaged or is removed from service , the remaining two can be operated in what is known as the open –delta or V-V connection .By being operated in this way , the bank still delivers three-phase currents and voltages in their correct phase relationship but the capacity of the bank is reduced to 57.70% of what it was with all three transformers in service .

(iii)  $\gamma$ - $\Delta$  connection – The  $\gamma$ - $\Delta$  connection shown in fig 8.72 is suitable for stepping down a high voltage . In this case , the primaries are designed for 57.7% of the high- tension line voltages.

(iv)  $\Delta$  –  $\gamma$  connection – The  $\Delta$  –  $\gamma$  connection shown in fig.....8.72 is commonly used for stepping up to a high voltage.

## OPEN-DELTA OR V-V CONNECTION

If one transformer breaks down in a star-star connected system of three single phase transformer , three phase power cannot be supplied until the defective transformer has been replaced or repaired . To eliminate this undesirable condition ,single phase transformer are generally connected delta- delta . In this case , if one transformer breaks down , it is possible to continue supplying three phase power with the other two transformers because his arrangement maintains correct voltage and phase relations on the secondary . However ,with two transformers ,the capacity of the bank is reduced to 57.7% of what it was with all three transformers in services (i.e. complete  $\Delta$  –  $\Delta$  circuit )

**THEORY-** If one transformer is removed in the  $\Delta$  –  $\Delta$  connection of three single phase transformers , the resulting connection becomes \*open delta or V-V connection . In complete  $\Delta$  –  $\Delta$  connection ,the voltage of any one phase is equal and opposite to the sum of the voltages of the other two phases .There fore , under no-load conditions if one transformer is removed , the other two will \*\* Maintain the same three line voltages on the secondary side . Under load conditions , the

secondary line voltages will be slightly unbalanced because of the unsymmetrical relation of the impedance drops in the transformers .

Fig 8.78 shows open delta (or V-V) connection ; one transformers shown dotted is removed .For simplicity , the load is consider to be star connected.

Figg8.78 shows the phasor diagram for voltages and currents . Here  $V_{AB}$ ,  $V_{BC}$  and  $V_{CA}$  represent the line –to –line voltages of the primary ;  $V_{ab}$ ,  $V_{bc}$  and  $V_{ca}$  represent the line –to –line voltages of the secondary  $V_{an}$ ,  $V_{bn}$  and  $V_{cn}$  represent the phase voltages of the load. For inductive load ,the load currents  $I_a$  ,  $I_b$  and  $I_c$  will lag the corresponding voltages  $V_{an}$ ,  $V_{bn}$  and  $V_{cn}$  by the load phase angle  $\phi$  .

The transformer windings ab and bc will deliver power given by;

$$P_{ab} = V_{ab}I_a \cos (30^\circ + \phi)$$

$$P_{bc} = V_{cb}I_c \cos (30^\circ - \phi)$$

$V_{ab} = V_{cb} = V$ , the voltage rating transformer secondary winding

$I_a = I_c = I$  , the current rating transformer secondary winding

P.F.=1 i.e.  $\phi=0^\circ$  ( For resistive load.)

$\therefore$  Power delivery to the resistive load by V-V connection is

$$P_v = P_{ab} + P_{bc} = VI \cos 30^\circ = 2VI \cos 30^\circ$$

With all three transformers connected in delta , the power delivered to the

Resistive load is  $P_\Delta = 3VI$

$$\frac{P_v}{P_\Delta} = \frac{2VI \cos 30^\circ}{3VI} = \frac{2 \cos 30^\circ}{3} = 0.577$$

Hence the power –handling capacity of a V-V circuit (without over heating the transformers ) is 57.7% of the capacity of a complete  $\Delta - \Delta$  circuit of the same transformers .

In a V-V circuit ,only 86.6% of the rated capacity of the two transformers is available . This can be readily proved .

$$\frac{\text{operating capacity}}{\text{available capacity}} = \frac{2VI \cos 30^\circ}{2VI} = \cos 30^\circ = \frac{\sqrt{3}}{2} = 0.866$$

Let us illustrate V-V connection with a numerical example .Suppose three identical single phase transformers , each capacity 10kVA, are connected in  $\Delta - \Delta$  . The total rating of the 3 transformers is 30kVA . When one transformer is removed ,the system reverts to V-V circuit and can deliver 3 phase power to a 3 phase load . How ever ,the kVA capacity of the V-V circuit is reduced to  $30 \times 0.577 = 17.3\text{kVA}$  and not 20kVA as might be expected . This reduced capacity can be determined in an alternate the available capacity of the two transformers is 20kVA .When operating in V-V circuit ,only 86.6% of the rated capacity is available that is  $20 \times 0.866 = 17.3\text{kVA}$ .

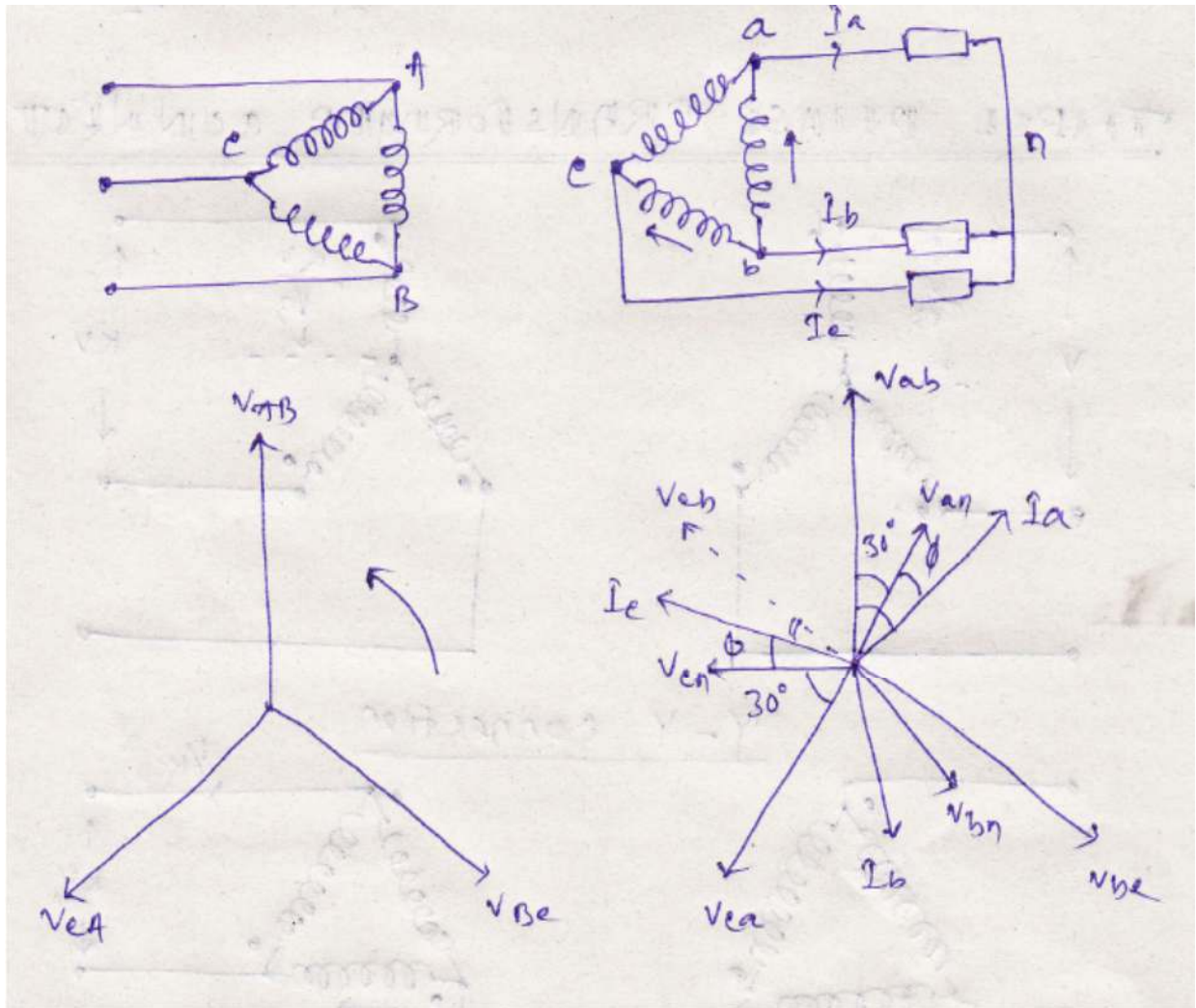

# PARALLEL OPERATION OF THREE-PHASE TRANSFORMER

All the conditions for the successful parallel operation of single phase transformers also apply to the parallel running of three phase transformers but with following addition : (i) The secondaries of all transformers must have the same phase sequence .

(ii) The phase displacement between primary and secondary line voltages must be the same for all transformers which are to be operated in parallel .

(iii) The secondaries of all transformer must have the same magnitude of line voltage .

The above 3 conditions must be strictly observed . If these conditions are not satisfied with ,the secondaries will simply short – circuit one another and no output will be possible. The main difficulty arising from the parallel connection of three 3 phase transformers is to ensure that condition (ii) is satisfied . For this , transformers in the same group should be connected in parallel.

